

1

FW2-NEO-8F

FW2-NEO-9F

**FREEWAVE™ WIRELESS PET IMMUNE
PIR DETECTOR**



INSTALLATION INSTRUCTIONS
7101770 Rev E

2

INTRODUCTION

The FW2-NEO-8F/9F is an advanced, fully supervised low-current wireless PIR detector that includes an advanced RF protocol for secure and reliable system operation.

The FW2-NEO-8F/9F has a unique ID code - compatible with FW2-TRANS transceiver that is designed to "learn" specific IDs and respond only to them.

The FW2-NEO-8F/9F includes APS mechanism for extending the battery live. (see below to learn more)

The FW2-NEO-8F/9F includes selectable 15 / 25kg pet immunity feature, activated below 1m.

The FW2-NEO-8F/9F includes series of messages for full communication administration (Supervision, Tamper, Low Batt.) as well as test transmission signals (communication, Tamper, alarm).

- 3
- ### FEATURES
- State-of-the-art 2 way wireless security system
 - Freewave2 advanced & secured RF protocol
 - Low current Technology
 - Powered by a single 3V Lithium battery
 - Battery life: up to 5 years
 - Frequency:
868.35MHz, 868.85MHz (FW2-NEO-8F) or 916.5MHz (FW2-NEO-9F)
 - Tamper Open/Close transmission
 - Supervision transmission
 - Battery status send on every transmission
 - Bi-Color LED indications for monitoring
 - Range up to 500m on open space.
 - Unique ID number
 - Front and back tamper.
 - PET immune up to 8m.

4

OPERATION

The Wireless PIR detector transmits the following events data:

SUPERVISION - a periodical transmission every 2 min. indicates detector's presence.

ALARM - Alarm transmission triggered by PIR intrusion detection.

LOW BAT - Whenever the battery reaches a pre-set low level (~2.4V) Battery Low signal will be sent with the next scheduled message (Supervisor, Alarm, etc.).

TAMPER - Whenever the cover is removed or placed back, a message will be transmitted with "Tamper" signal.

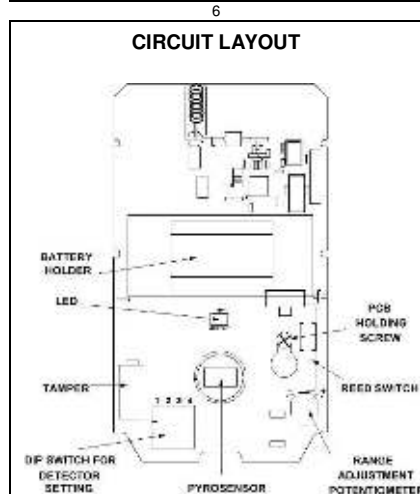
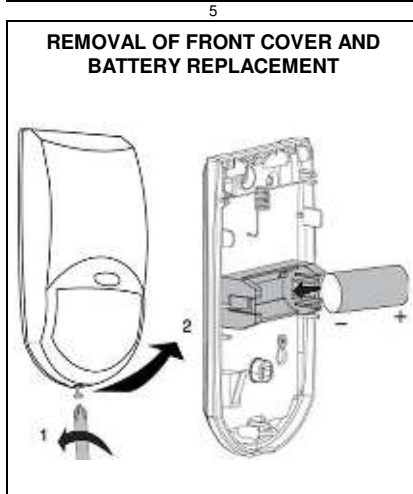

7

SETTING THE DETECTOR

- LED Enable / Disable**
ON- Position (Up) - enables LED's indications for each transmitted event.
OFF Position (Down) - disable LED's indications

NOTE: THE STATE OF THE SWITCH "LED" DOES NOT AFFECT THE OPERATION OF LED ON START-UP, WALK TEST, CRITICAL LOW BAT INDICATION, AND DEVICE TROUBLE INDICATION

- PULSE - "Sensitivity Adjustment"** use for setting the PULSE count function in order to provide PIR sensitivity control according to the environment.
OFF - "1" High sensitivity. For stable environments.
ON - "2" Low sensitivity. For harsh environments.

8

SETTING THE DETECTOR - CONT.

- APS:** Automatic Power Saver function enables a battery life span up to 5 years. The detector will transmit only when the last event has occurred more than 2 minutes prior to the current one.
- PET - "Pet Immunity Adjustment"** use for setting the PET Immune level to 15Kg or 25Kg.
OFF- Immunity to an animal up to 15 kg
ON - Immunity to an animal up to 25 kg
- Range Adjust:** "PIR" POTENTIOMETER - adjustment according to protected area range. Use the Potentiometer to adjust the detection sensitivity between 30% and 100%, according to walk test in the protected area. Rotate the potentiometer clockwise to increase range, counter-clockwise to decrease range. After adjusting the sensitivity perform a walk test to verify optimum correct sensitivity in the protected area.

9

ID REGISTRATION

Refer to the system transceiver's installation instructions and follow the procedure given there for "learning" detector IDs.

Place battery as instructed & wait until start up LED stops blinking.

Make sure that the transceiver is on learning mode according to control panel installation instruction. Generate a transmission by pressing and releasing tamper switch - this will start the "learn" data transmitting by the device to the control panel transceiver.

Note the LED indications on the device:

- **Green/red LED flashes alternately** - for 5 sec PIR was registered successfully cover may be closed only after verification with control panel.
- **Green LED blinks periodically** - Device was not signed into FW2-TRANSCIEVER. Repeat installation process
- **Red LED blinks** - for over 20sec Battery voltage is critically low. Replace battery

10

RSSI - RF SIGNAL INDICATION

The FREEWAVE2 control panel has "RF Signal Strength Indication" (RSSI) for each transceiver in order to help the installer to define the best location for the detector from RF perspective.

The indication value is between 1 and 100, where 100 is the best RF received signal. If the RSSI indication value is less than 30, it is a sign for a weak RF link and it is recommended to find a better installation for the FW2-NEO-8F/9F.

NOTES:
Supported only on selected Crow CP.

11

MOUNTING THE DETECTOR

1. Choose a location most likely to intercept an intruder - see detection pattern.
2. To remove the front cover, unscrew the holding screw and pull out the cover by tilting from bottom out.
3. Mount the detector base: place 4 screws and make sure you tighten the tamper screw (the middle screw) easily, so the back tamper switch will press the switch successfully when PCB is placed back - over winding may result in false mechanical adaptation and lack of tamper press.
4. Place the CR123A BAT confirming the correct polarity.
5. Place the cover by inserting it back into appropriate position and tilting bottom side in.
6. Fasten the holding screw.

AVOID THE FOLLOWING LOCATIONS
Facing direct sunlight.
Facing areas that may change temperature rapidly.
Areas where there are air ducts or substantial airflows.
The FW2-NEO-8F/9F performs better when provided with a constant and stable environment.

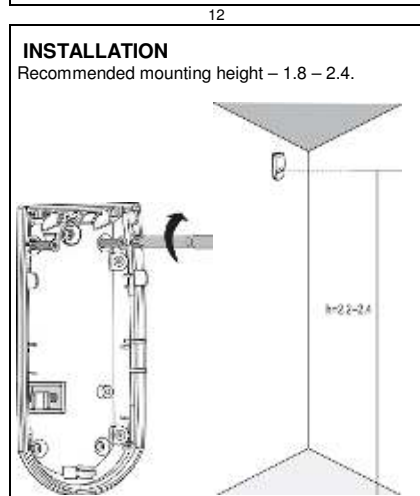

TRANSMISSION TESTS

Tamper transmission test.

Change of the tamper switch state will cause tamper transmissions. Verify it on the control panel indications.

Communication signal test.

Check the RF Communication quality (RSSI). Special indication at the control panel that displays continuously the received RF signal quality.

Reed switch test

The reed switch is located at the lower right side of the detector (front view). It is used to activate the walk and RF transmission test of the detector. Use magnet to activate the test mode by placing it near the FW2-NEO-8F/9F lower right side till red/ green led blinks are observed

DETECTION PATTERN

The detector detects motion crossing the beam. It is more sensitive detecting motions crossing the beams then moving toward the detector.

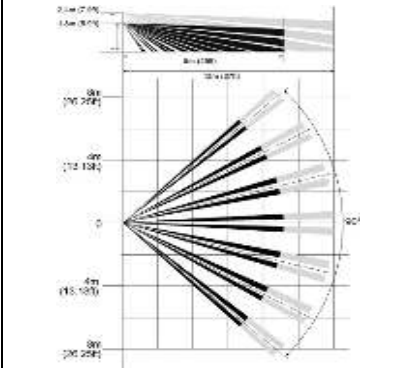

REGULATORY APPROVALS

The FW2-NEO-8F/9F conforms to the essential requirements set out by:

- RTTE directive:1999/5/EC
- EMC directive: 2004/108/EC
- Low Voltage directive: 2006/95/EC

Harmonized Standards applicable to this products are:

- EN300220-2
- EN301489-3
- EN301489-1
- EN50130-4:1995+A1(1998)+A2(2003)
- EN61000-6-3
- EN60950-1



Additional Standards and Directives applicable to this product are:

- RoHS directive: 2002/95/EC
- EN50131-1
- EN50131-2-2
- EN50131-5-3
- EN50130-5



Security Grade2, Environmental Class II

CROW ELECTRONIC ENGINEERING LTD. ("Crow") - WARRANTY POLICY CERTIFICATE

This Warranty Certificate is given in favor of the purchaser (hereunder the "Purchaser") purchasing the products directly from Crow or from its authorized distributor.

Crow warrants these products to be free from defects in materials and workmanship under normal use and service for a period of 24 months from the last day of the week and year whose numbers are printed on the printed circuit board inside these products (hereunder the "Warranty Period"). Subject to the provisions of this Warranty Certificate, during the Warranty Period, Crow undertakes, at its sole discretion and subject to Crow's procedures, as such procedures are from time to time, to repair or replace, free of charge for materials and/or labor, products proved to be defective in materials or workmanship under normal use and service. Repaired products shall be warranted for the remainder of the original Warranty Period. All transportation costs and in-transit risk of loss or damage related, directly or indirectly, to products returned to Crow for repair or replacement shall be borne solely by the Purchaser.

Crow's warranty under this Warranty Certificate does not cover products that is defective (or shall become defective) due to: (a) alteration of the products (or any part thereof) by anyone other than Crow; (b) accident, abuse, negligence, or improper maintenance; (c) failure caused by a product which Crow did not provide; (d) failure caused by software or hardware which Crow did not provide; (e) use or storage other than in accordance with Crow's specified operating and storage instructions.

There are no warranties, expressed or implied, of merchantability or fitness of the products for a particular purpose or otherwise, which extend beyond the description on the face hereof.

This limited Warranty Certificate is the Purchaser's sole and exclusive remedy against Crow and Crow's sole and exclusive liability toward the Purchaser in connection with the products, including without limitation - for defects or malfunctions of the products. This Warranty Certificate replaces all other warranties and liabilities, whether oral, written, (non-mandatory) statutory, contractual, in tort or otherwise.

In no case shall Crow be liable to anyone for any consequential or incidental damages (inclusive of loss of profit, and whether occasioned by negligence of the Crow or any third party on its behalf) for breach of this or any other warranty, expressed or implied, or upon any other basis of liability whatsoever. Crow does not represent that these products can not be compromised or circumvented; that these products will prevent any person injury or property loss or damage by burglary, robbery, fire or otherwise; or that these products will in all cases provide adequate warning or protection.

Purchaser understands that a properly installed and maintained product may in some cases reduce the risk of burglary, fire, robbery or other events occurring without providing an alarm, but it is not insurance or a guarantee that such will not occur or that there will be no personal injury or property loss or damage as a result. Consequently, Crow shall have no liability for any personal injury; property damage or any other loss based on claim that these products failed to give any warning.

If Crow is held liable, whether directly or indirectly, for any loss or damage with regards to these products, regardless of cause or origin, Crow's maximum liability shall not in any case exceed the purchase price of these products, which shall be the complete and exclusive remedy against Crow.

WALK TEST

Walk test mode can be activated remotely from selected alarm systems by entering to the walk test mode or it can be activated locally by the approximating a magnet for 1 sec and removing it, the LED will blink red follows by green 6 times, Transmission will activate on the every detection. During walk test mode green led will blink to indicate device is in walk test mode
The test mode period is 2 min if activated locally by magnet and up to 15 min if activated remotely. At the end of the test mode the LED's will blink red & green fast 6 times to indicate the end of the Test.

APS – AUTOMATIC POWER SAVE

The unique APS (Automatic Power Saver) function built in the detector enables a battery life span up to 5 years. The detector will transmit only when the last event has occurred more than 2 minutes prior to the current one.

FCC & IC STATEMENT

FCC ID: **NFC-FW2NEO9F**
IC: **8164A-FW2NEO9F**

This device complies with FCC Rules Part 15 and with Industry Canada license-exempt RSS standard(s). Operation is subject to two conditions: (1) This device may not cause harmful interference, and (2) this device must accept any interference that may be received or that may cause undesired operation.

Canada: Le présent appareil est conforme aux CNR d'Industrie Canada applicables aux appareils radio exempts de licence. L'exploitation est autorisée aux deux conditions suivantes : (1) l'appareil ne doit pas produire de brouillage, et (2) l'utilisateur de l'appareil doit accepter tout brouillage radioélectrique subi, même si le brouillage est susceptible d'en compromettre le fonctionnement.

WARNING:

Changes or modifications to this equipment not expressly approved by the party responsible for compliance (Crow Electronic Engineering Ltd.) could void the user's authority to operate the equipment.

TECHNICAL SPECIFICATIONS

Data Protocol	FreeWave2
Modulation Type	GFSK (2 frequencies)
Frequency	868.35MHz, 868.85MHz / 916.5 MHz
Identification	Unique ID serial number – 24 bit
Event Transmission	Alarm, Tamper, Supervision, Low Bat.
Detection Method	PIR
Range in open space	500m
Battery	Lithium. 3V Type: CR123A Size: 2/3AA
Battery life expectancy	>4 years @ APS mode
Low Battery	~2.4VDC
Current Consumptions:	
Standby	~10 µA
Receive mode	~22 mA
Transmit mode	~32 mA
Transmit power:	~10dBm
Tamper Switch	Front Cover Removal; Back Tamper
Operating temperature	-10°C to +50°C
Dimensions	123mm x 62mm x 38mm
Weight (inc. battery)	120 gr.

BATTERY REPLACEMENT

- Remove the front cover.
 - Pull out the old battery.
 - Install a new battery according to polarity marking.
 - After assembling the battery the LED will flash green then red alternately for 45 seconds. During this time the detector does not function, wait until the LED stops flashing.
 - Press tamper switch for 2 sec and release.
- Green/Red LED flashes 6 times alternately:**
The detector was successfully registered in system.

The cover may be placed back and closed.

Green LED blinks 20 times:

No response from Transceiver / device was not assigned on CP - Repeat installation procedure.

Red LED blinks continually (over 20 sec):
Battery voltage is critical low, device won't function - Replace battery.

FCC & IC STATEMENT (Continue)

Note: The digital circuit of this device has been tested and found to comply with the limits for a Class B digital device, pursuant to part 15 of the FCC Rules. These limits are designed to provide reasonable protection against harmful interference in a residential installation. This equipment generates uses and can radiate radio frequency energy and, if not installed and used in accordance with the instructions, may cause harmful interference to radio communications. However, there is no guarantee that interference will not occur in a particular installation. If this equipment does cause harmful interference to radio or television reception, which can be determined by turning the equipment off and on, the user is encouraged to try to correct the interference by one or more of the following measures:
-Reorient or relocate the receiving antenna.
-Increase the separation between the equipment and receiver.
-Connect the equipment into an outlet on a circuit different from that to which the receiver is connected.
-Consult the dealer or an experienced radio/TV technician for help.

CAUTION !!!

RISK OF EXPLOSION IF BATTERY IS REPLACED BY DIFFERENT TYPE / MODEL.
DISPOSE USED BATTERIES ACCORDING TO ITS INSTRUCTIONS

The battery must be replaced by 3V Lithium battery Size 2/3A Models such as:

1. VARTA CR123A
2. GP CR123A

CROW ELECTRONIC ENGINEERING LTD.

12 Kineret St.
Airport City, 70100 Israel
Tel. +972 3 9726000
Fax. +972 3 9726001
sales@crow.co.il
support@crow.co.il
www.thecrowgroup.com

CROW LATIN AMERICA USA INC.

7200 NW 19 st.
Suite 307
Miami Fl 33126, USA
Tel. +305 513 4001
Fax. +305 513 4005
rejane@crowlatinamerica.com
www.crowlatinamerica.com

ARROWHEAD ALARM PRODUCTS

344B, Rosedale Road
Park Farm Industrial Estate
Albany, Auckland
New Zealand
Tel. +64 9 414 0085
Fax. +64 9 414 0088
www.aap.co.nz

These instructions supersede all previous issues in circulation prior to November 2012.