



Electromechanical Locking Solutions

Side Load Locks,
Drop Bolts,
Electric Strikes,
Electromagnetic
Locks, Speciality
Locking, Cable
Transfers and
Switches

Symbols



CE Rated
Complies with the requirements of the relevant European health, safety and environmental protection legislation



C-Tick Approved
Applies to electrical and electronic devices, indicating compliance with relevant labelling notices and product standards



Fire Rating
A range of electric strikes and electromagnetic locks are fire rated and comply with AS1905.1.

The electric strikes and electromagnetic locks have been tested on fire door assemblies in accordance with Australian Standards. Please refer to fire door manufacturer for specific approved details.

Table of contents



01 Side Load Locks



02 Drop Bolts



03 Electric Strikes



04 Electromagnetic Locks



05 Speciality Locks



06 Cable Transfers



07 Switches

SL30DBL

COBALT Electronic Side Load Lock

The electronic side load lock, COBALT, is a motor driven electronic lock designed to secure commercial and residential double action doors.

The lock addresses the two biggest issues in door locking; the ability to align a misaligned door and the ability to release when requested, even with excessive load on the door. Reliable, secure, convenient.

Features

- Door misalignment of up to 8mm is corrected
- Side load release - up to 100kgs
- Automatic deadbolting
- Two, 10mm thick stainless steel bolt pin
- Reverse polarity and transient protection
- Multiple attempts to lock
- Convert from fail safe to fail secure by repositioning a single jumper
- Door and bolt position monitors
- Mortise mount horizontally or vertically, on double acting doors
- Surface mount with the aid of the SL30DBL accessories, including mounting onto glass

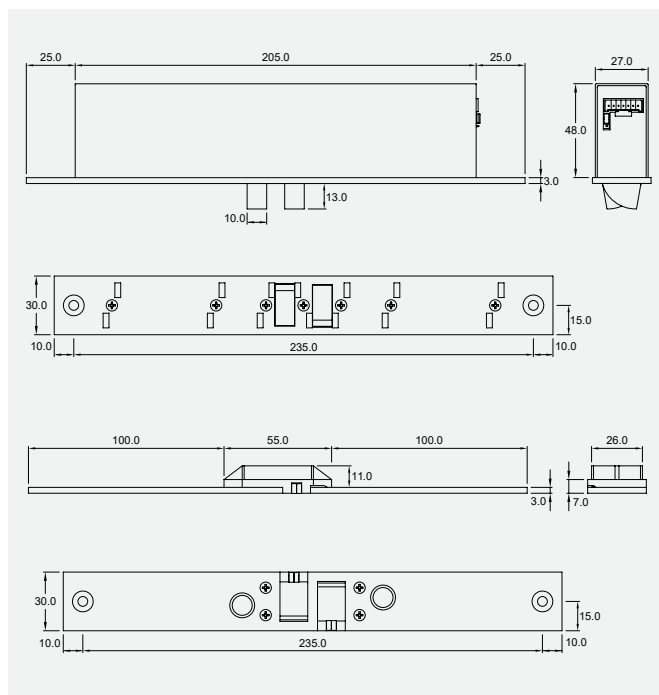

Dimensions - Lock

Item	Article Number	Description
SL30DBL	9400000003117	SL30DBL COBALT LOCK 12-24VDC MNTD
SL30DBL to retrofit V Lock		
SL30VDBL	9400000003460	SL30DBL COBALT FOR V LOCK RETROFIT

Specifications

Lock	255L x 30W x 51D(mm)
Long Strike	255L x 30W x 14D(mm)
Housing	258L x 34W x 55D(mm)
Dress Plate	260L x 0.7W x 58D(mm)
Holding Force	10,000N (1000Kg)
Door Misalignment	+/- 8mm
Side Load Release	Up to 100kg opening load on door
Voltage at Lock	12 - 24VDC +/-15%
Current Usage	
Holding	<50mA@12V, <30mA@24V
Operating	<250mA@12V, <200mA@24V
Stall	<1A@12V, <0.5A@24V
Monitors Switches	
Bolt Position	30VDC, 0.1A
Door Position	100VDC, 0.5A
Endurance	300,000 cycles normal operation

SL30SGL

COBALT - mini Electronic Side Load Lock

The electronic side load lock, COBALT-mini, is a motor driven electronic lock designed to secure commercial and residential single action doors.

Its small footprint ensures the Cobalt-mini can be installed in most locations however it still has the ability to pull a door in tightly against a seal and will release instantly when requested, even with excessive load on the door.

Features

- Door misalignment of up to 8mm is corrected
- Side load release - up to 100kgs
- Automatic deadbolting
- 10mm thick stainless steel bolt pin
- Reverse polarity and transient protection
- Multiple attempts to lock
- Convert from fail safe to fail secure by repositioning a single jumper
- Door and bolt position monitors
- Mortice mount horizontally or vertically, on single acting doors
- Surface mount with the aid of the SLA30SGL accessories, including mounting onto glass



Specifications

Lock	160L x 30W x 51D(mm)
Long Strike - SLA213H	160L x 30W x 14D(mm)
Housing - SLA214J	163L x 34W x 55D(mm)
Dress Plate - SLA216J	165L x 0.7W x 58D(mm)
Holding Force	10,000N (1000Kg)
Door Misalignment	Up to 8mm
Side Load Release	Up to 100kg opening load on door
Voltage at Lock	12 - 24VDC +/-15%
Current Usage	
Holding	<50mA@12V, <30mA@24V
Operating	<250mA@12V, <200mA@24V
Stall	<1A@12V, <0.5A@24V
Monitors Switches	
Bolt Position	30VDC, 0.1A
Door Position	100VDC, 0.5A
Endurance	300,000 cycles normal operation

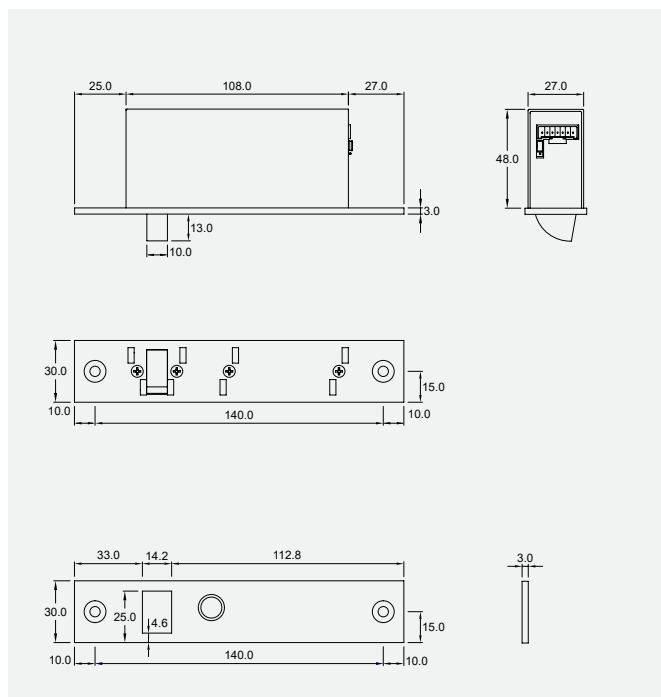

Dimensions - Lock

Item	Article Number	Description
SL30SGL	9400000003118	SL30SGL COBALT MINI LOCK 12-24VDC MNTD
SL30SGL to retrofit V Lock		
SL30VSGL	9400000003459	SL30SGL COBALT MINI FOR V LOCK RETROFIT

Side Load Locks

Accessories - SL30 Series



SLA203H
Long Square Hole Strike
255L x 30W x 14D(mm)



SLA204J
Housing
258L x 34W x 55D(mm)



SLA206J
Dress Plate
260L x 0.7W x 58D(mm)



SLA213H
Long Square Hole Strike
160L x 30W x 14D(mm)



SLA214J
Housing
163L x 34W x 55D(mm)



SLA216J
Dress Plate
165L x 0.7W x 58D(mm)

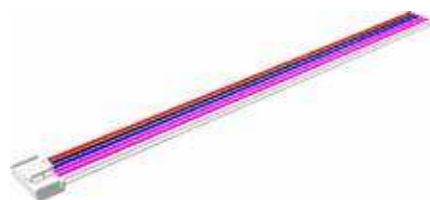

YNL209
SL30DBL/SL30SGL
Wire Loom

Item	Article Number	Description
SLA203H	9400000003119	SLA203H LONG SQR HOLE STRIKE FOR SL30DBL
SLA204J	9400000003120	SLA204J SURF FIX HOUSING FOR SL30DBL
SLA206J	9400000003121	SLA206J DRESS PLATE SL30DBL
SLA213H	9400000003122	LONG SQUARE HOLE STRIKE FOR SL30SGL
SLA214J	9400000003123	SLA214J SURF FIX HOUSING FOR SL30SGL
SLA216J	9400000003124	SLA216J DRESS PLATE FOR SL30SGL
YNL209	9400000003305	COBALT SL30DBL/SL30SGL WIRE LOOM

DB25

Electronic Deadbolt Lock

The DB25 incorporates advanced design, quality and electronic ingenuity to provide a secure, yet versatile, door locking device.

With integrated access control features and robust engineering, the DB25 is a high security streamlined lock suitable for use on any single or double acting door.

Features

- Automatic deadbolting
- 12.7mm diameter stainless steel bolt pin
- Anti-tailgate and Anti-tamper
- Auto-relock after 0/3/6/9 seconds
- Multiple attempts to lock and unlock
- Thermal overheating protection
- Reverse polarity and transient protection
- Dual monitoring with door and bolt position monitors
- Mortice mount horizontally or vertically, on single or double acting doors
- Surface mount with the aid of the DB25 accessories, including mounting onto glass

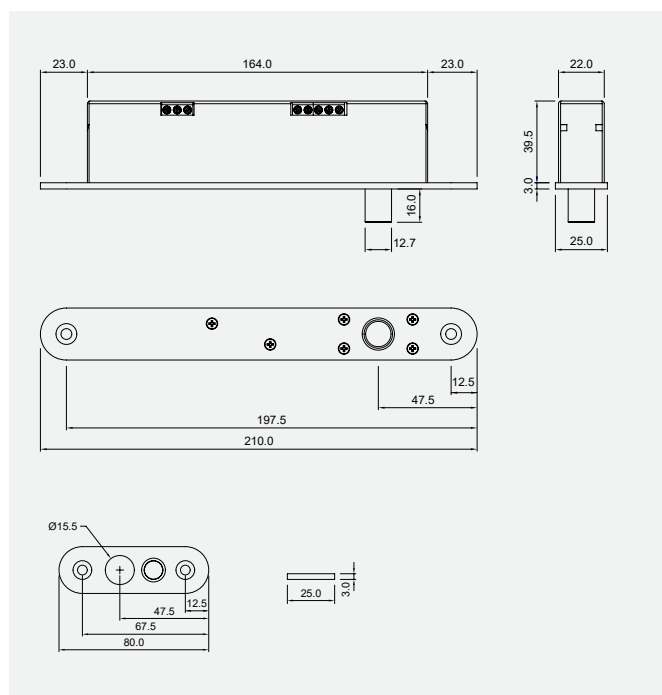

Dimensions - Lock



Specifications

Lock	210L x 25W x 42D(mm)
Short Strike - DBA103A	80L x 25W x 3D(mm)
Long Strike - DBA103E	210L x 25W x 3D(mm)
Housing - DBA104J	225L x 29W x 46.5D(mm)
Dress Plate - DBA106J	225L x 0.7W x 50D(mm)
Holding Force	10,000N (1000Kg)
Voltage at Lock	12 - 24VDC +/-10%
Current Usage	
Holding	160mA@12V, 95mA@24V
Operating	1.25A@12V, 1A@24V
Monitors Switches	
Bolt Position	25VDC, 0.5A
Door Position	100VDC, 0.5A
Endurance	Cycle tested to 1000000 operations
Materials	Plastics: POM, Stainless Steel: 304

Item	Article Number	Description
DB25PTL	9400000003473	DB25PTL D/BOLT 12-24VDC F/SAFE MONT'D
DB25PTO	9400000003474	DB25PTO D/BOLT 12-24VDC F/SECURE MNT'D

DB25L

Electronic Deadbolt Lock - Mag-latch

The DB25L incorporates a unique latching device that is a world first in electronic deadbolts.

Door alignment problems vanish with the innovative design which ensures the correct positioning of the lock and strike every time. Incorporating access control functions, and the highest quality componentry

Features

- Dual Action - magnetic latch to capture the door and deadbolt to secure the door
- Automatic deadbolting
- 12.7mm diameter stainless steel bolt pin
- Anti-tailgate and Anti-tamper
- Auto-relock after 0/3/6/9 seconds
- Multiple attempts to lock and unlock
- Thermal overheating protection
- Reverse polarity and transient protection
- Dual monitoring with door and bolt position monitors
- Mortise mount horizontally or vertically, on single or double acting doors
- Surface mount with the aid of the DB25L accessories, including mounting onto glass



Specifications

Lock	210L x 25W x 42D(mm)
Long Strike - DBA133E	210L x 25W x 3D(mm)
Housing - DBA104J	225L x 29W x46.5D(mm)
Dress Plate - DBA106J	225L x 0.7W x 50D(mm)
Holding Force	10,000N (1000Kg)
Voltage at Lock	12 - 24VDC +/-10%
Current Usage	
Holding	160mA@12V, 95mA@24V
Operating	1.25A@12V, 1A@24V
Monitors Switches	
Bolt Position	25VDC,0.5A
Door Position	100VDC, 0.5A
Endurance	Cycle tested to 1000000 operations
Materials	Plastics: POM, Stainless Steel: 304

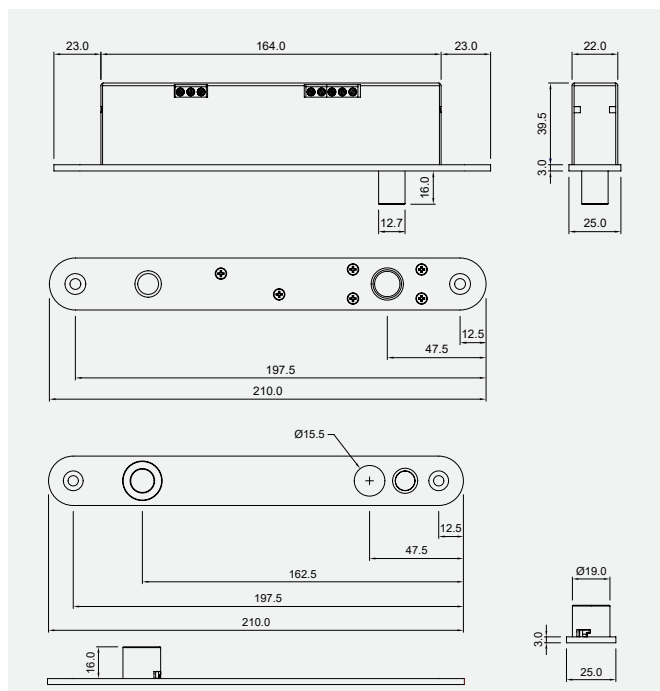

Dimensions - Lock

Item	Article Number	Description
DB25LPTL	9400000001816	DB25L D/BOLT W/LATCH 12-24VDC F/SAFE MTD
DB25LPTO	9400000001817	DB25L D/BOLT W/LATCH 12-24VDC F/SEC MTD

DB25K

Electronic Deadbolt Lock

Incorporates the same advanced design, quality and electronic ingenuity as the DB25 with the added flexibility of a manual key override.

Despite the addition of the key override mechanism the streamlined design is maintained allowing the DB25K to provide a high security, yet versatile, door locking solution.

Features

- A Euro style key cylinder can be used to manually control the lock
- Automatic deadbolting
- 12.7mm diameter stainless steel bolt pin
- Anti-tailgate and Anti-tamper
- Auto-relock after 0/3/6/9 seconds
- Multiple attempts to lock and unlock
- Thermal overheating protection
- Reverse polarity and transient protection
- Dual monitoring with door and bolt position monitors
- Mortice mount horizontally or vertically, on single or double acting doors
- Surface mount with the aid of the DB25K accessories, including mounting onto glass

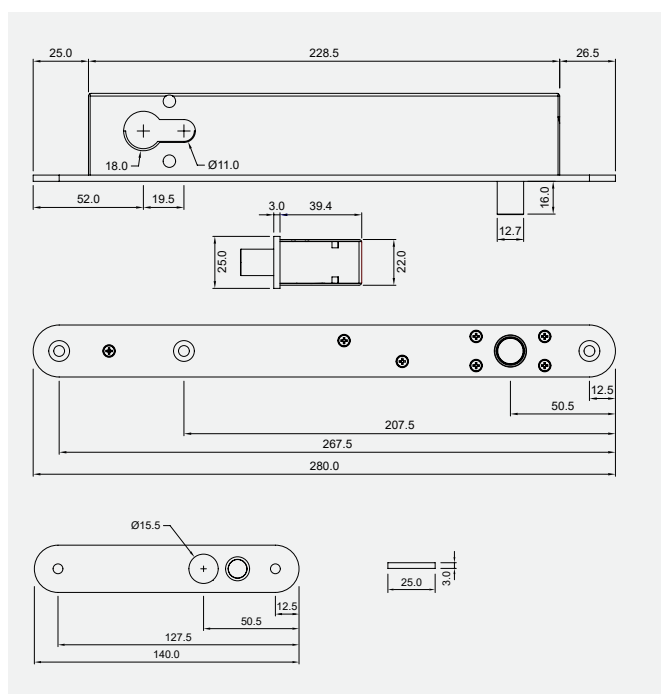

Dimensions - Lock

Item	Article Number	Description
DB25KPTL	9400000001814	DB25K D/BOLT KEY O/R 12-24VDC F/SAFE MTD
DB25KPTO	9400000001815	DB25K D/BOLT KEY O/R 12-24VDC F/SEC MTD



Specifications

Lock	280L x 25W x 42D(mm)
Short Strike - DBA143A	140L x 25W x 3D(mm)
Long Strike - DBA143E	280L x 25W x 3D(mm)
Bolt Housing - DBA144J	294L x 29W x 46.5D(mm)
Strike Housing - DBA145J	294L x 29W x 46.5D(mm)
Dress Plate - DBA146J	294L x 0.7W x 50D(mm)
Holding Force	10,000N (1000Kg)
Voltage at Lock	12 - 24VDC +/-10%
Current Usage	
Holding	160mA@12V, 95mA@24V
Operating	1.25A@12V, 1A@24V
Monitors Switches	
Bolt Position	25VDC, 0.5A
Door Position	100VDC, 0.5A
Endurance	Cycle tested to 1000000 operations
Materials	Plastics: POM, Stainless Steel: 304

DB38

Electronic Deadbolt Lock - Heavy Duty

Offering the highest level of security with increased strength, primarily achieved by utilizing a larger diameter bolt pin, the DB38 is the preferred option when high physical strength is required.

Incorporating advanced design, quality and electronic ingenuity to provide a secure, yet versatile, door locking device suitable for use on any single or double acting door.

Features

- Automatic deadbolting
- 14.2mm diameter stainless steel bolt pin
- Anti-tailgate and Anti-tamper
- Auto-relock after 0/3/6/9 seconds
- Multiple attempts to lock and unlock
- Thermal overheating protection
- Reverse polarity and transient protection
- Dual monitoring with door and bolt position monitors
- Mortise mount horizontally or vertically, on single or double acting doors
- Surface mount with the aid of the DB38 accessories, including mounting onto glass



Specifications

Lock	203L x 37.5W x 44D(mm)
Short Strike - DBA173C	90L x 30W x 3D(mm)
Long Strike - DBA173G	203L x 37.5W x 3D(mm)
Housing - DBA174J	206L x 41W x 49D(mm)
Dress Plate - DBA176J	210L x 0.7W x 50D(mm)
Holding Force	20,000N (2000Kg)
Voltage at Lock	12 - 24VDC +/-10%
Current Usage	
Holding	230mA@12V, 90mA@24V
Operating	1.5A@12V, 1.4A@24V
Monitors Switches	
Bolt Position	25VDC, 0.5A
Door Position	100VDC, 0.5A
Endurance	Cycle tested to 1000000 operations
Materials	Plastics: POM, Stainless Steel: 304

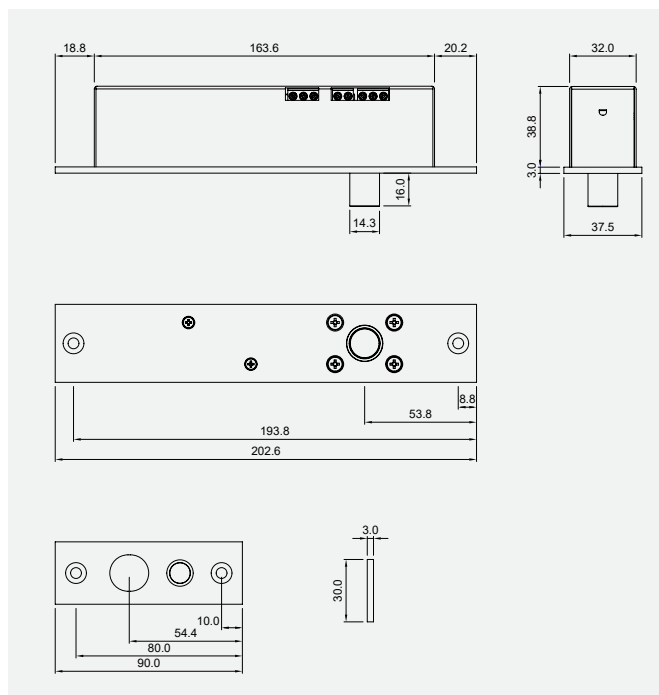

Dimensions - Lock

Item	Article Number	Description
DB38PTL	9400000001820	DB38PTL D/BOLT 12-24VDC F/SAFE MNT'D
DB38PTO	9400000001821	DB38PTO D/BOLT 12-24VDC F/SECURE MNT'D

DB38L

Electronic Deadbolt Lock - Mag-latch

The DB38L brings together two critical features; the highest holding force of any of the door lock range of products and the innovative latching device designed to align the door.

First the magnetic latch ensures the correct positioning of the lock and strike before the DB38L activates and secures the door with its deadbolting pin.

Features

- Dual Action - magnetic latch to capture the door and deadbolt to secure the door
- Automatic deadbolting
- 14.2mm diameter stainless steel bolt pin
- Anti-tailgate and Anti-tamper
- Auto-relock after 0/3/6/9 seconds
- Multiple attempts to lock and unlock
- Thermal overheating protection
- Reverse polarity and transient protection
- Dual monitoring with door and bolt position monitors
- Mortise mount horizontally or vertically, on single or double acting doors
- Surface mount with the aid of the DB38L accessories, including mounting onto glass

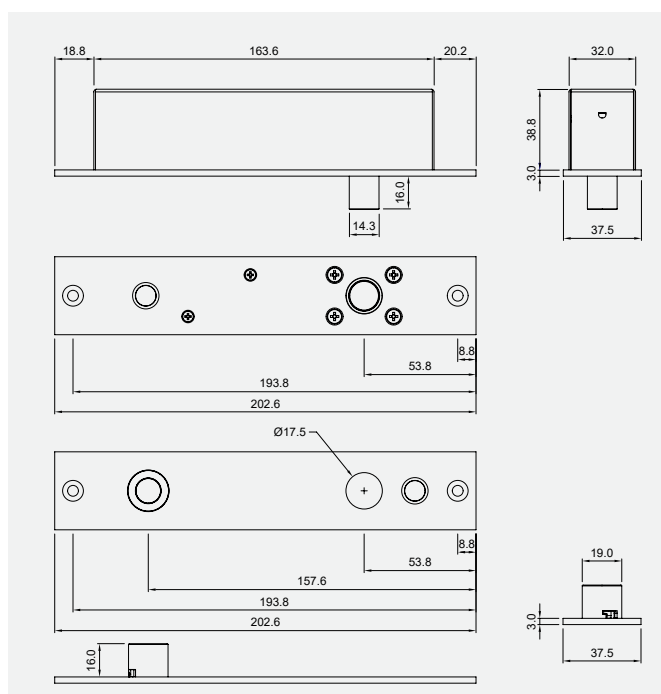

Dimensions - Lock

Item	Article Number	Description
DB38LPTL	940000001818	DB38L D/BOLT W/LATCH12-24VDC F/SAFE MTD
DB38LPTO	940000001819	DB38L D/BOLT W/LATCH 12-24VDC F/SEC MTD



Specifications

Lock	203L x 37.5W x 44D(mm)
Long Strike - DBA183G	203L x 37.5W x 19D(mm)
Housing - DBA174J	206L x 41W x 49D(mm)
Dress Plate - DBA176J	210L x 0.7W x 50D(mm)
Holding Force	20,000N (2000Kg)
Voltage at Lock	12 - 24VDC +/-10%
Current Usage	
Holding	230mA@12V, 90mA@24V
Operating	1.5A@12V, 1.4A@24V
Monitors Switches	
Bolt Position	25VDC, 0.5A
Door Position	100VDC, 0.5A
Endurance	Cycle tested to 1000000 operations
Materials	Plastics: POM, Stainless Steel: 304

Drop Bolt

Accessories - DB25 Series



DBA103A
Short Strike
80L x 25W x 3D(mm)



DBA103E
Long Strike
210L x 25W x 3D(mm)



DBA104J
Housing
225L x 29W x 46.5D(mm)



DBA106J
Dress Plate
225L x 0.7W x 50D(mm)



DBA133E
Long Round Hole Strike
210L x 25W x 3D(mm)



DBA143A
Short Round Hole Strike
140L x 25W x 3D(mm)



DBA143E
Long Round Hole Strike
280L x 25W x 3D(mm)



DBA144J
Bolt Housing
294L x 29W x 46.5D(mm)



DBA145J
Strike Housing
294L x 29W x 46.5D(mm)



DBA146J
Dress Plate
294L x 0.7W x 50D(mm)

Item	Article Number	Description
DBA103A	9400000003475	DBA103A SHORT STRIKE ROUND DB25
DBA103E	9400000003476	DBA103E LONG STRIKE ROUND DB25
DBA104J	9400000001822	DBA104J SURF FIX HOUSING DB25/DB25L
DBA106J	9400000001823	DBA106J DRESS PLATE FOR DB25/DB25L
DBA133E	9400000003477	DBA133E LONG RND HOLE STRIKE FOR DB25L
DBA143A	9400000003478	DBA143A SHORT RND HOLE STRIKE FOR DB25K
DBA143E	9400000003479	DBA143E LONG RND HOLE STRIKE FOR DB25K
DBA144J	9400000003480	DBA144J SURF FIX HOUSING FOR DB25K BOLT
DBA145J	9400000003481	DBA145J SURF HOUSING FOR DB25K STRIKE
DBA146J	9400000003482	DBA146J DRESS PLATE FOR DB25K

Drop Bolt

Accessories - DB 38 Series



DBA173C
Short Round Hole Strike
90L x 30W x 3D(mm)



DBA173G
Long Round Hole Strike
203L x 37.5W x 3D(mm)



DBA174J
Housing
206L x 41W x 49D(mm)



DBA176J
Dress Plate
210L x 0.7W x 50D(mm)



DBA183G
Long Round Hole Strike

Item	Article Number	Description
DBA173C	9400000003483	DBA173C SHORT RND HOLE STRIKE FOR DB38
DBA173G	9400000001824	LONG ROUND HOLE STRIKE FOR DB38
DBA176J	9400000003484	DBA176J DRESS PLATE FOR DB38/DB38L
DBA174J	9400000009885	DBA174J SURF FIX HOUSING FOR DB38/DB38L
DBA183G	9400000003485	DBA183G LONG RND HOLE STRIKE FOR DB38L

KES100

Non Monitored Electric Strike

The KES100 Series ANSI electric strike is an economical choice, offering dual voltage 12/24V as standard and an interchangeable fail safe/fail secure feature.

It is constructed of solid zinc alloy housing, a stainless steel keeper and stainless steel face plate. Designed for use with large selection of morticed type locks and has a keeper depth of 16mm. Also included in the package is a 202mm long faceplate, making a single model suitable for all types of wooden, steel and aluminium door frames. Supplied as standard with trim plate to cover any damage to frame during installation.

Features

- Fail safe/fail secure interchangeable
- Dual voltage 12/24VDC
- 16mm keeper (allowing 19mm latch throw)
- Includes long face plate for timber frame installation
- Includes trim plate
- Holding force 700kgs (1500lbs) specification
- Optional lip extension brackets are available for wide door jamb



Specifications

Short Face Plate	124L x 43.5W x 29.5D(mm)
Long Face Plate	202L x 43.5W x 29.5D(mm)
Holding strength	700kgs
Operating voltage	12/24VDC
Voltage tolerance	+/-15%
Current draw	250mA/12VDC, 150mA/24VDC
Operating temperature	-10° C ~ +45°C
Humidity	0~95%
Latch throw	19mm
Material	Zinc alloy body stainless steel faceplate and keeper

Electric Strikes

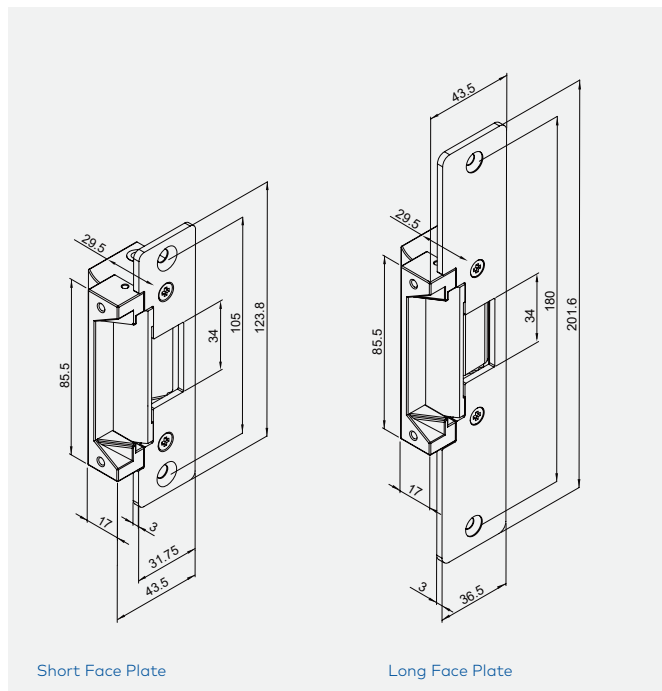

Dimensions - Lock

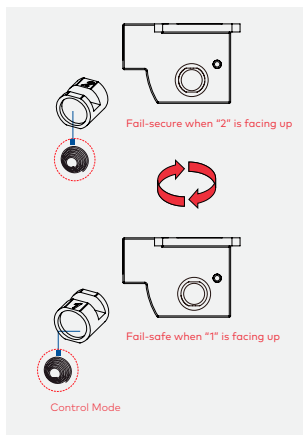

Version Changeable

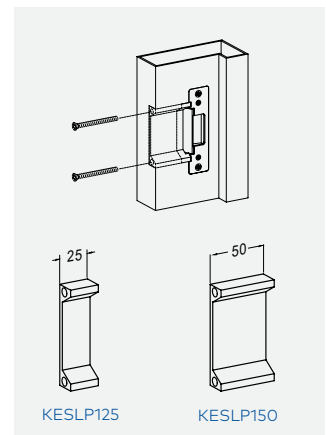

Optional Accessories

Item	Article Number	Description
KES100	940000002461	ANSI SIZE ELEC STRIKE 12/24VDC NON MTD

KES1500

Rim Mounted Electric Strike

The KES1500 Series rim mounted electric strike is an economical choice, offering dual voltage 12/24V as standard and an interchangeable fail safe/fail secure feature.

It is constructed of a solid zinc alloy housing, stainless steel keeper and stainless steel face plate. Designed for use with a large selection of rim mounted lock types. Suitable for wood framed and hollow metal doors.

Features

- Fail safe/fail secure interchangeable
- Dual voltage 12/24V
- Suits latch depth up to 15mm
- Holding force: up to 900kg (2000lb)



Specifications

Lock	62L x 86W x 28.5D (mm)
Holding strength	900kgs
Operating voltage	12/24VDC
Voltage tolerance	+/-15%
Current draw	0.25 A/12VDC: 0.15 A/24VDC (at temperature 20°C)
Operating temperature	-10° C ~ +45°C
Humidity	0-95% non-condensing
Cycle Tested	to 1 million cycles
Material	Zinc alloy body stainless steel faceplate & release lip

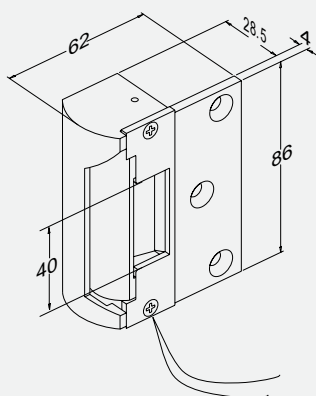

Dimensions - Lock

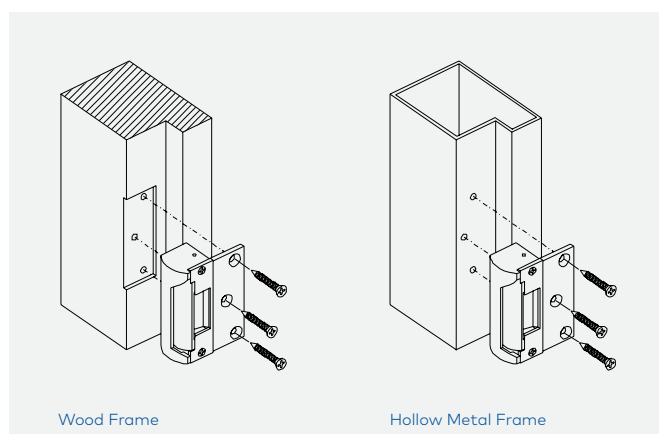

Typical Installation

Item	Article Number	Description
KES1500	940000002462	RIM MOUNT ELEC STRIKE 12/24VDC NON MTD

KES200Z

Non Monitored Electric Strike

The KES200Z Series is an economical electric strike, designed for use with a large selection of mortice, key in knob and key in lever type locks in both timber and metal frames.

The KES200Z also offers variable voltage from 12VAC/DC to 28VAC/DC as well as a fast and convenient interchangeable fail safe/fail secure function (changeable on site). The unit comes pre-drilled for the optional extension lips. Also included in package is an installation kit for metal frame installation.

Features

- Fail safe/fail secure interchangeable
- Variable voltage 12~28VAC/DC
- Suits latch depth up to 15mm
- Pre-drilled for optional extension lips
- Includes mounting tabs for metal frame
- Static holding force 800kgs (1750lbs)



Specifications

Lock	175L x 44W x 27D(mm)
Holding strength	800kgs
Operating voltage	12~28VAC/DC
Voltage tolerance	+/-15%
Current draw	230mA/12VDC, 140mA/28VDC 440mA/12VAC, 230mA/28VAC
Operating temperature	-10° C ~ +45°C
Humidity	0-95% non-condensing
Cycle Tested	to 1 million cycles
Material	Zinc alloy housing stainless steel keeper

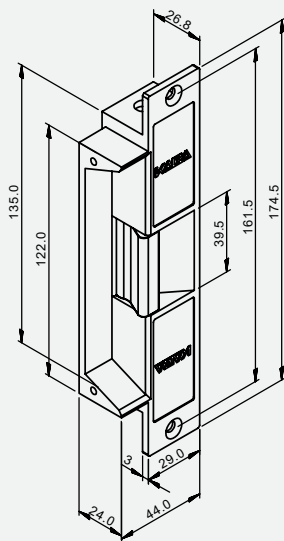

Dimensions - Lock

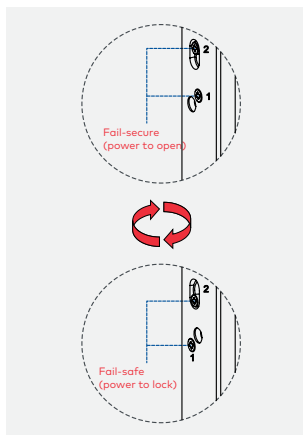

Version Changeable

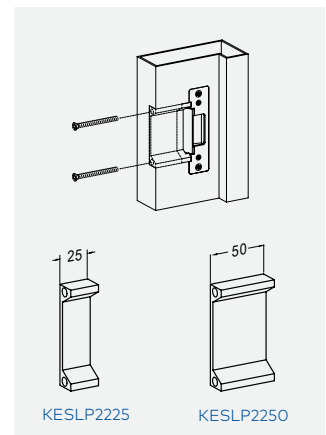

Optional Accessories

Item	Article Number	Description
KES200Z	9400000002463	ELEC STRIKE Z/ALLOY 12-28VDC/AC NON MTD

KES2200

Fully Monitored Electric Strike

The KES2200 Series is a high security electric strike, offering a single model including switch monitoring of latch, keeper and solenoid, variable voltage from 12VDC/AC to 28VDC/AC, a fast and convenient interchangeable fail safe/fail secure function (changeable on site).

The construction of housing and keeper are of stainless steel and include pre-drilled holes for optional extension lips. Also included in package is an installation kit for metal frame installation.

Features

- Fail safe/fail secure interchangeable
- Variable voltage 12~24VDC
- Suits latch depth up to 15mm
- Monitored latch, keeper and solenoid
- Pre-drilled for optional extension lips
- Includes mounting tabs for metal frame
- Solid stainless steel construction
- Static holding force 920kgs (2000lbs)



Specifications

Lock	175L x 44W x 27D(mm)
Holding strength	920kgs
Operating voltage	12-24VDC
Voltage tolerance	+/-15%
Current draw	230mA/12VDC, 140mA/28VDC 440mA/12VAC, 230mA/28VAC
Latch/Keeper Micro Switch Rating	1A/125VAC
Operating temperature	-10° C ~ +45° C
Humidity	0-95% non-condensing
Cycle Tested	to 1 million cycles
Material	stainless steel housing and keeper

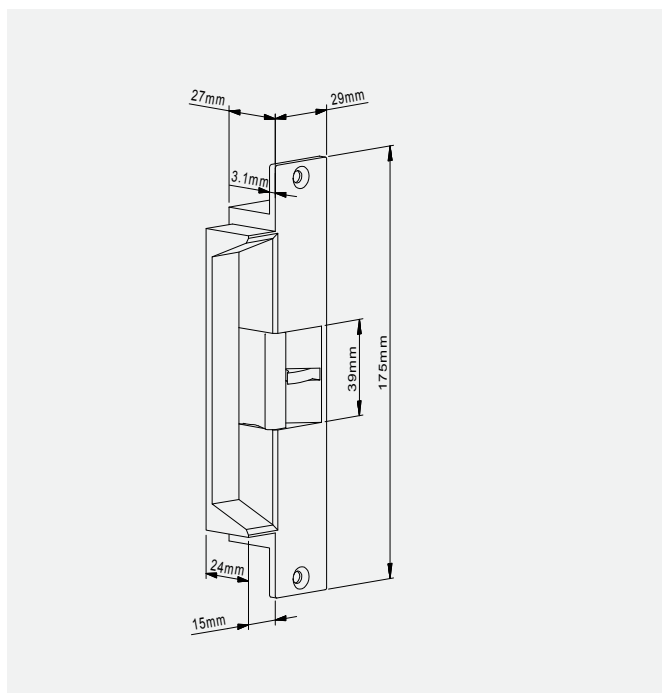

Dimensions - Lock

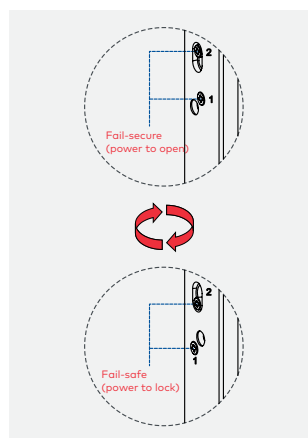

Version Changeable

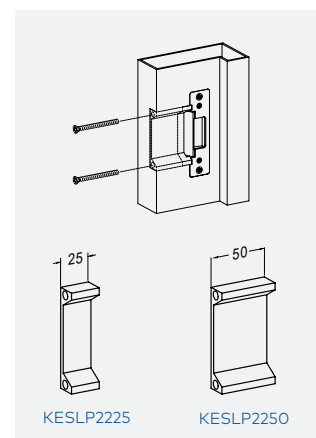

Optional Accessories

Item	Article Number	Description
KES2200	940000002464	ELEC STRIKE H/DUTY 12-28VDC/AC MTD

KES900S

Preload Electric strike – Monitored Stainless Steel

The KES900S Electric strike with pre-load feature is capable of opening when activated with up to 35kgs of pressure. Commonly caused by air conditioning, doors that have dropped or warped or the addition of door seals. Constructed of Stainless-Steel housing and keeper offering a high level of security that can withstand up to 1000kgs of static force

The KES900S offers dual voltage of 12VDC/24VDC and includes convenient fail safe/Fail secure function (changeable on site). Also included are pre-drilled holes for optional extension lips and installation tabs for metal frame.

Features

- Field reversible fail-safe/fail-secure
- Operating voltage 12VDC/24VDC
- Monitored latch & lock status
- Suits latch throw up to 18mm
- Preload – Up to 35kg (80lbs)
- Pre-drilled for optional extension lips
- Includes mounting tabs for metal frame
- Stainless steel construction (Fire-rated)
- Static holding force of 1000kg (2200lbs)



Specifications

Lock	1745L x 44W x 27D(mm)
Holding strength	680kgs
Preload	35kg
Operating voltage	12/24VDC
Voltage tolerance	+/-15%
Current draw	600mA/12VDC, 300mA/24VDC
Operating temperature	-10° C ~ +49°C
Humidity	0-85% non-condensing
Operating mode	fail secure/fail secur
Cycle Tested	to 1 million cycles
Material	Zinc alloy housing stainless steel keeper

Electric Strikes

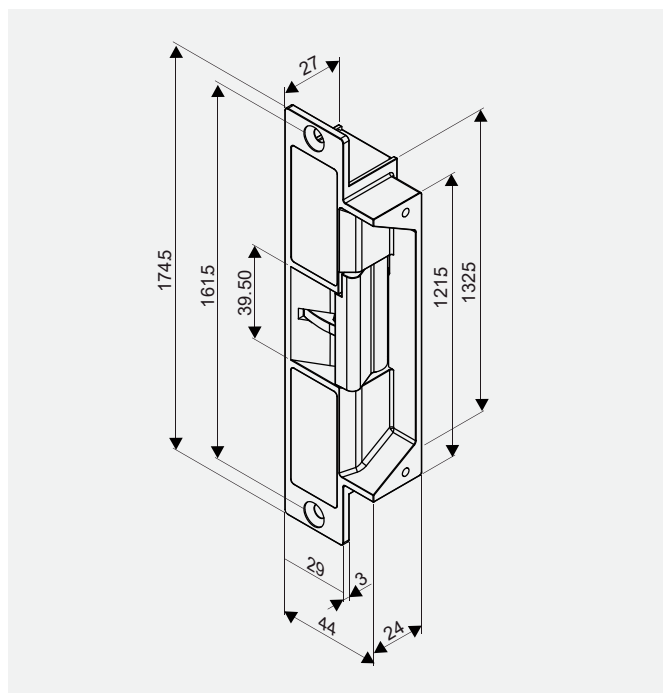

Dimensions - Lock

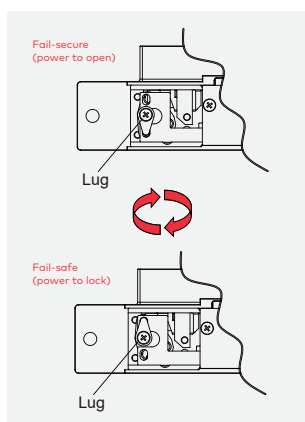

Version Changeable

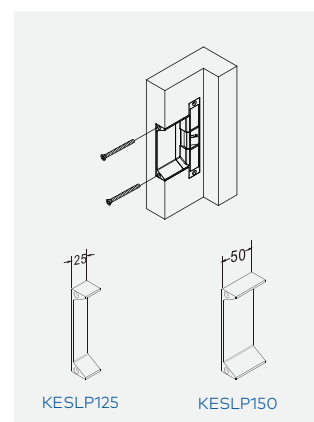

Optional Accessories

Item	Article Number	Description
KES900S	9400000012900	KES900S Electric Strike SS MTD 12/24VDC

KES900Z

Preload Electric strike – Monitored Zinc Alloy

The KES900Z Electric strike provides a pre-load function capable of opening electrically with up to 35kgs of pressure being applied, commonly caused by air conditioning, doors that have dropped or warped or the addition of door seals. Due to the Zinc Alloy construction it is an economic solution, perfectly suited for Non fire-rated applications such as residential & aluminium fabricated solutions.

The KES900Z offers dual voltage of 12VDC/24VDC and includes convenient fail safe/Fail secure function (changeable on site). Also included are pre-drilled holes for optional extension lips and installation kit for metal frame installation.

Features

- Field reversible fail-safe/fail-secure
- Operating voltage 12VDC/24VDC
- Monitored latch & lock status
- Suits latch throw up to 18mm
- Preload – Up to 35kg (80lbs)
- Pre-drilled for optional extension lips
- Includes mounting tabs for metal frame
- Zinc Alloy construction (Non fire-rated)
- Static holding force of 680kg (1500lbs)



Specifications

Lock	1745L x 44W x 27D(mm)
Holding strength	1000kgs
Preload	35kg
Operating voltage	12/24VDC
Voltage tolerance	+/-15%
Current draw	600mA/12VDC, 300mA/24VDC
Operating temperature	-10° C ~ +49° C
Humidity	0-85% non-condensing
Operating mode	fail secure/fail secur
Cycle Tested	1 million cycles
Material	stainless steel housing stainless steel keeper

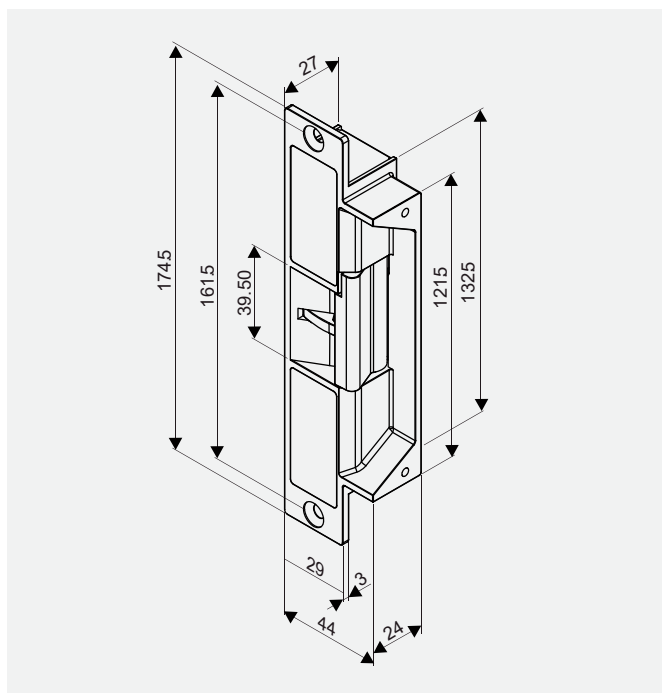

Dimensions - Lock

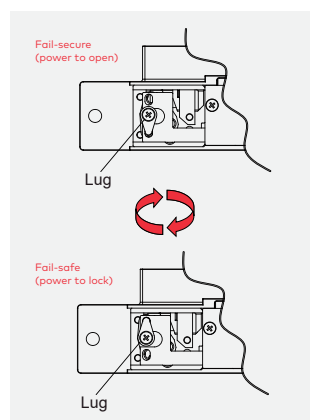

Version Changeable

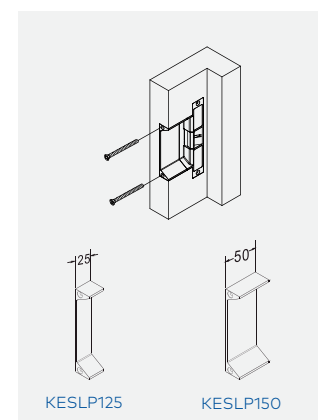

Optional Accessories

Item	Article Number	Description
KES900Z	9400000012901	KES900Z Electric Strike ZINC MTD 12/24VDC

Electric Strikes

Accessories



KESLP125
Lip Extension 25mm



KESLP150
Lip Extension 50mm



KESLP2225
Lip Extension 25mm



KESLP2250
Lip Extension 50mm

Item	Article Number	Description
KESLP125	9400000005656	LIP EXT 25MM FOR KES100, KES900S/900Z
KESLP150	9400000005657	LIP EXT 50MM FOR KES100, KES900S/900Z
KESLP2225	9400000002465	LIP EXT 25MM FOR KES2200/200Z
KESLP2250	9400000002466	LIP EXT 50MM FOR KES2200/200Z

KML-2

Morticed Type Electromagnetic Lock

The KML-2 is a morticed type electromagnetic lock which can be used on single and double sliding doors.

It has a holding force 270KGS and dual voltage with both lock and door sensor. It also features a built-in voltage spike suppressor and is C-Tick, UL Listed and CE approved.

Features

- Mortised Type - single door, sliding door and double action door
- Built-in voltage spike suppressor
- Door status sensor (reed switch)
- Anti Residual magnetism device (ARM)



Specifications

Lock	228L x 38W x 27D(mm)
Armature plate	185L x 38W x 12.5T(mm)
Holding Force	2,700N (270Kg)
Voltage	12/24VDC
Current draw	500mA/12VDC, 250mA/24VDC
Material	Brushed anodized aluminium housing Zinc plated steel armature

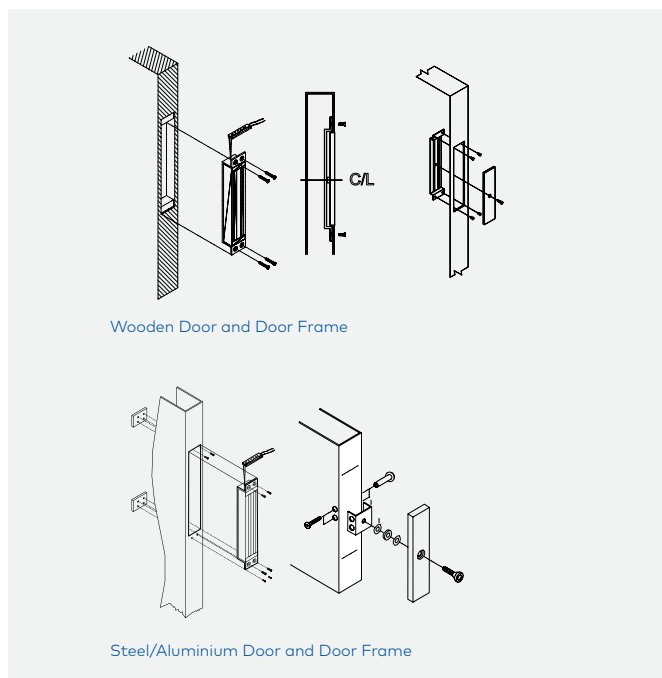

Wooden Door and Door Frame

Steel/Aluminium Door and Door Frame

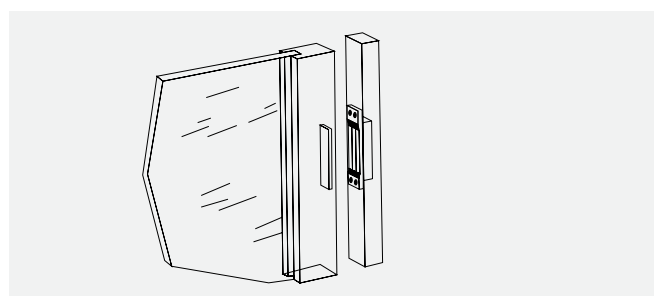

Installation Positions - Double Doors

Typical Installation

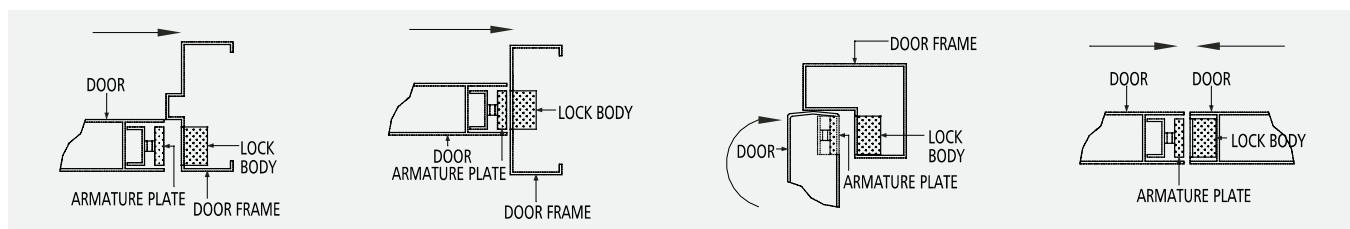

Applications

Item	Article Number	Description
KML-2	940000002515	KML-2 EML 270KG MORTISE SGL/SLIDE/DBL

Electromagnetic

KML-2H

Electromagnetic Lock

The KML-2H is a surface mounted electromagnetic lock which can be used on single doors.

It has a holding force 270KGS and dual voltage with both lock and door sensor. It also features a built-in voltage spike suppressor and an LED Monitor. It is C-Tick, UL Listed and CE approved, with a 2 hour fire rating.

Features

- Surface mounted - Single doors
- Built-in voltage spike suppressor
- LED monitor
- Lock sensor (hall effect IC)
- Door sensor
- Anti residual magnetism device (ARM)



Specifications

Lock	250L x 42W x 26D(mm)
Armature plate	185L x 38W x 12.5T(mm)
Holding Force	2,700N (270Kg)
Voltage	12/24VDC
Current draw	500mA/12VDC, 250mA/24VDC
Material	Brushed anodized aluminium housing Zinc plated steel armature

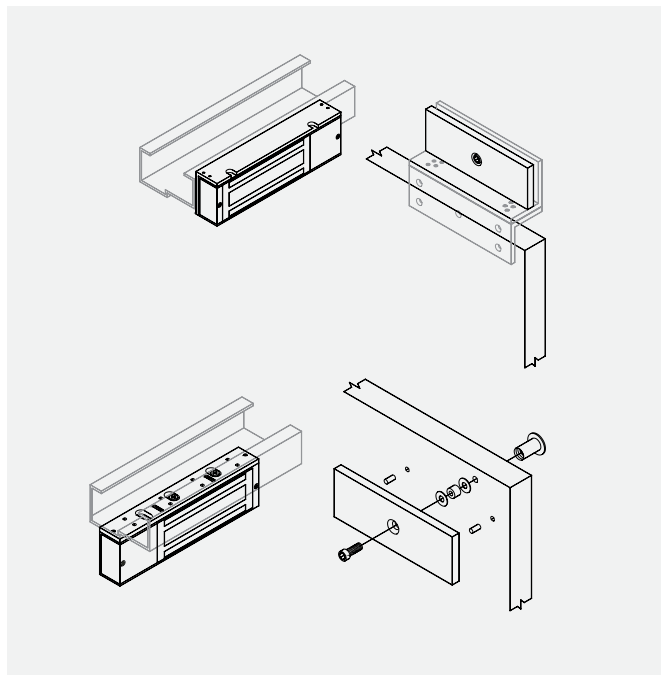

Typical Installation

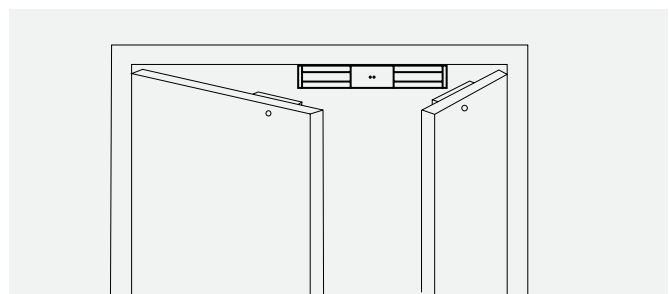

Installation Positions - Double Doors

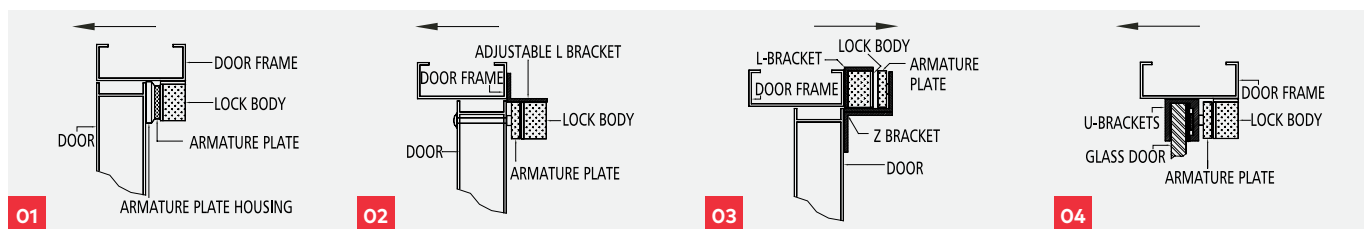

01 ARMATURE PLATE HOUSING

01
Use B0011
Armature Plate Housing

02 ADJUSTABLE L BRACKET

02
Use B1011
L Adjustable Bracket

03 L-BRACKET LOCK BODY ARMATURE PLATE

03
Use B1012
L & Z Bracket

04 U-BRACKETS LOCK BODY

04
Use U185
U Bracket for Glass Door

Item	Article Number	Description
KML-2H	9400000002516	KML-2H EML 270KG SURF MOUNT/SINGLE DOOR

KML-6

Electromagnetic Lock

The KML-6 is a surface mounted electromagnetic lock which can be used on single doors.

It has a holding force 540KGS and dual voltage with both lock and door sensor. It also features a built-in voltage spike suppressor and is CTick, UL Listed, CE approved and has a 2 hour fire rating.

Features

- Surface mounted - Single doors
- LED monitor
- Built-in voltage spike suppressor
- Lock sensor (hall effect IC)
- Door status sensor (reed switch)
- Anti residual magnetism device (ARM)



Specifications

Lock	*266L x 73W x 40D(mm) *including mounting plate
Armature plate	185L x 61W x 16T(mm)
Holding Force	5,400N (540Kg)
Voltage	12/24VDC
Current draw	500mA/12VDC, 250mA/24VDC
Material	Brushed anodized aluminium housing Zinc plated steel armature

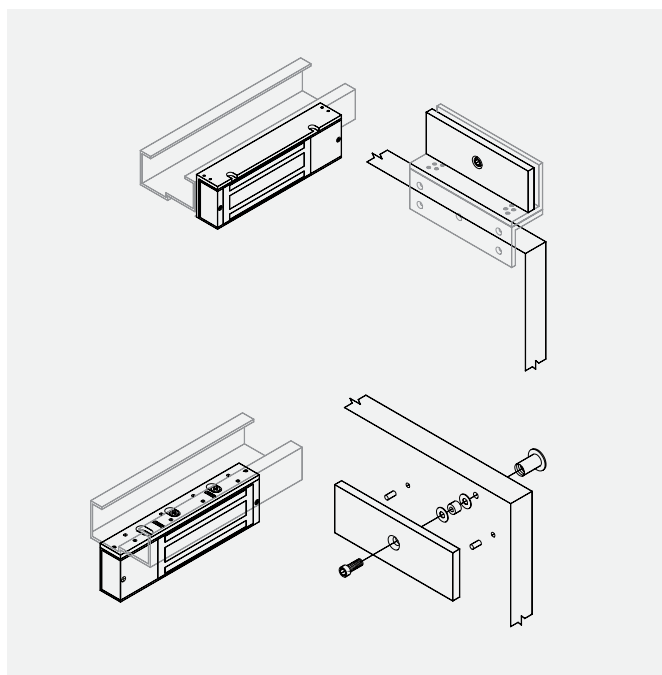

Typical Installation

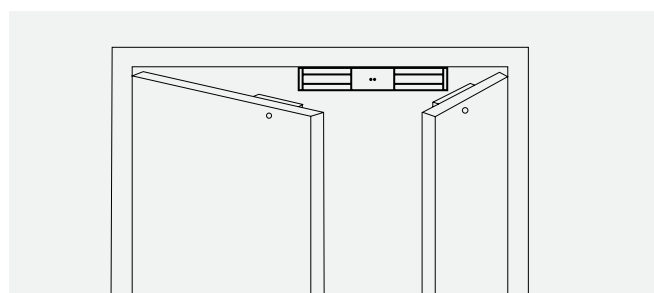

Installation Positions - Double Doors

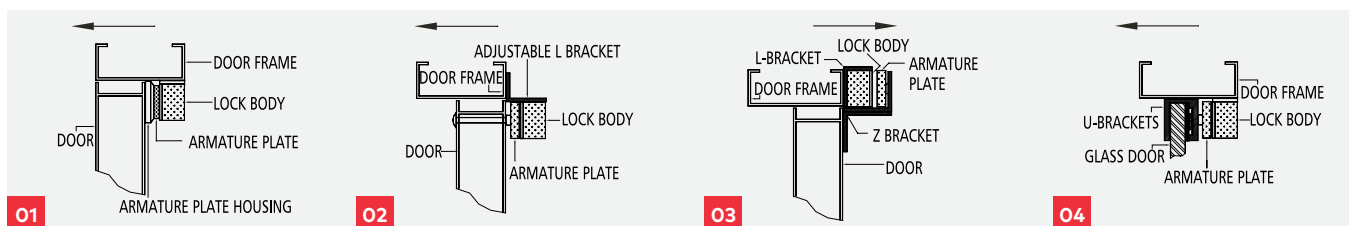

01 ARMATURE PLATE HOUSING

01
Use B0001
Armature Plate Housing

02 ADJUSTABLE L BRACKET

02
Use B1001
L Adjustable Bracket

03 L-BRACKET LOCK BODY ARMATURE PLATE Z BRACKET

03
Use B1002
L & Z Bracket

04 U-BRACKETS GLASS DOOR ARMATURE PLATE

04
Use U185
U Bracket for Glass Door

Item	Article Number	Description
KML-6	9400000002518	KML-6 EML 540KG SURF MOUNT/SINGLE DOOR

Electromagnetic

KML-10

Electromagnetic Lock

The KML-10 is a surface mounted double electromagnetic lock which can be used for double doors.

It has a holding force 540KGS and dual voltage with both lock and door sensor. It also features a built-in voltage spike suppressor and is C-Tick, UL Listed, CE approved and has a 2 hour fire rating.

Features

- Surface mounted - Double doors
- LED monitor
- Built-in voltage spike suppressor
- Hall effect monitoring
- Lock sensor (hall effect IC)
- Door status sensor (reed switch)
- Anti residual magnetism device (ARM)

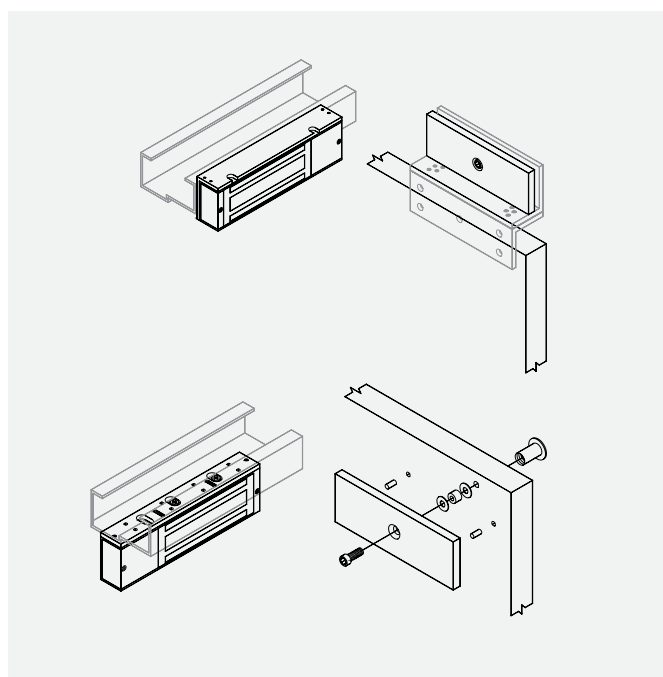

Specifications

Lock	*532L x 73W x 40D(mm) *including mounting plate
Armature plate	185L x 61W x 16T(mm)
Holding Force	5,400N (540Kg)
Voltage	12/24VDC
Current draw	500mA/12VDC, 250mA/24VDC
Material	Brushed anodized aluminium housing Zinc plated steel armature

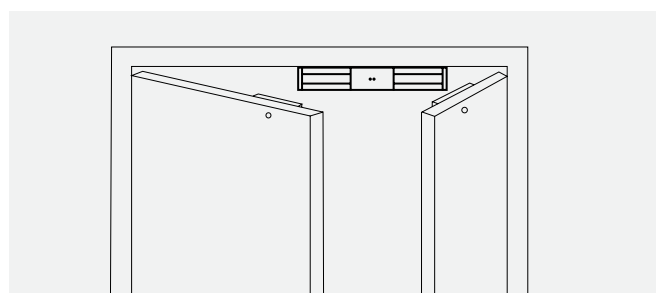

Typical Installation

Installation Positions - Double Doors

Note: For double door applications select 2 of each accessory.

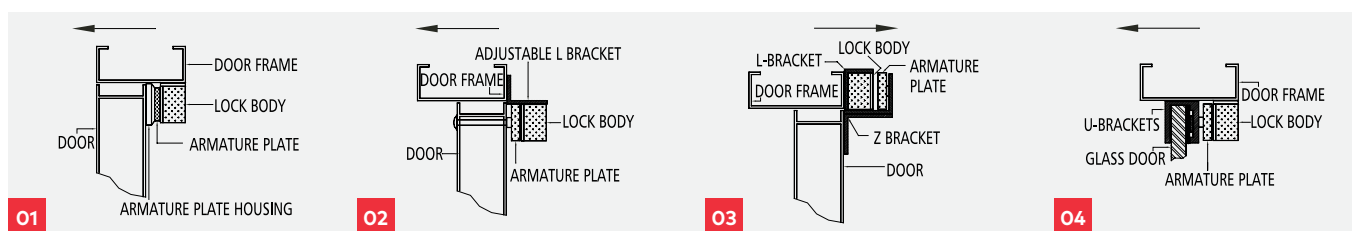

01 ARMATURE PLATE HOUSING

01
Use B0001
Armature Plate Housing

02 ADJUSTABLE L BRACKET

02
Use B1001
L Adjustable Bracket

03 L-BRACKET LOCK BODY ARMATURE PLATE Z BRACKET

03
Use B1002
L & Z Bracket

04 U-BRACKETS LOCK BODY ARMATURE PLATE GLASS DOOR

04
Use U185
U Bracket for Glass Door

Item	Article Number	Description
KML-10	9400000002514	KML-10 EML 540KG SURF MOUNT/DOUBLE DOOR

KML-CCW30

Electromagnetic Lock

The KML-CCW30 is a surface mounted electromagnetic lock which can be used on single doors.

It has a holding force 135KGS and dual voltage with lock sensor. It also features a built-in voltage spike suppressor and is C-Tick, UL Listed and CE approved, with a 2 hour fire rating.

Features

- Surface mounted - Single doors
- Built-in voltage spike suppressor
- LED monitor
- Lock sensor (hall effect IC)



Specifications

Lock	*165L x 38.5W x 21D(mm) *including mounting plate
Armature plate	130L x 32W x 8T(mm)
Holding Force	1350N (135Kg)
Voltage	12/24VDC
Current draw	360mA/12VDC, 180mA/24VDC
Material	Brushed anodized aluminium housing Zinc plated steel armature

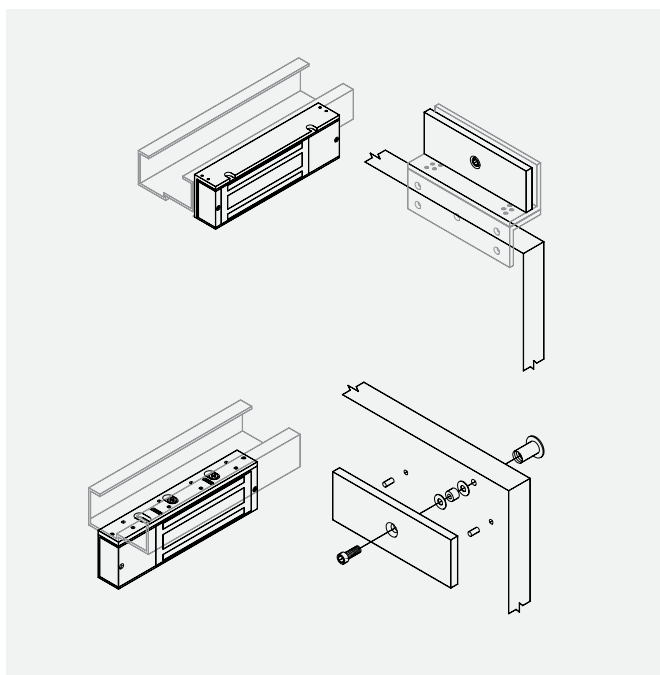

Typical Installation

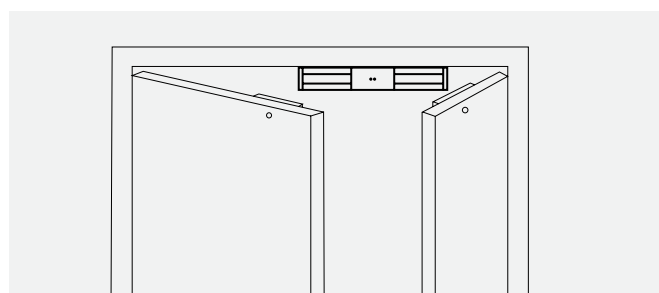

Installation Positions - Double Doors

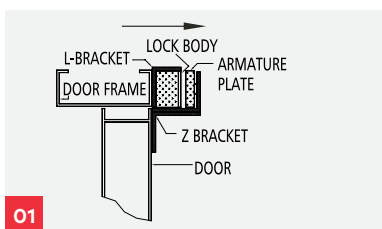

01
Use B1022
L & Z Bracket

Item	Article Number	Description
KML-CCW30	9400000002519	KML-CCW30 EML 135KG SURF MOUNT/SGL DOOR

Electromagnetic

KML-CCW30F

Morticed Type Electromagnetic Lock

The KML-CCW30F is a morticed type electromagnetic lock which can be used for single and double sliding action doors.

It has a holding force of 135KGS and dual voltage with lock sensor. It also features a built-in voltage spike suppressor and is UL Listed and CE approved.

Features

- Mortised type - Single door, sliding door and double action door
- Built-in voltage spike suppressor
- Lock sensor (hall effect IC)

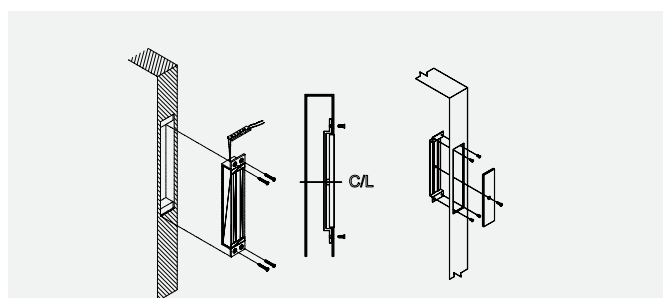

Wooden Door & Door Frame

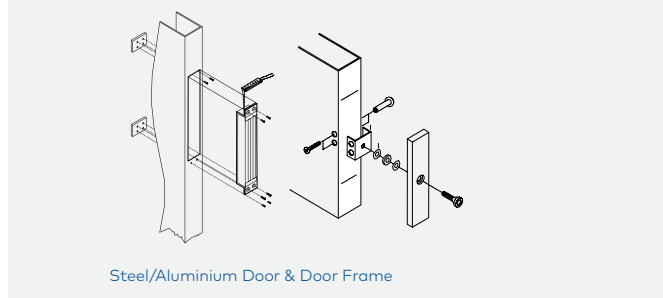

Steel/Aluminium Door & Door Frame

Specifications

Lock	202L x 34.5W x 21D(mm)
Armature plate	130L x 32W x 8T(mm)
Holding Force	1350N (135Kg)
Voltage	12/24VDC
Current draw	360mA/12VDC, 180mA/24VDC
Material	Brushed anodized aluminium housing Zinc plated steel armature

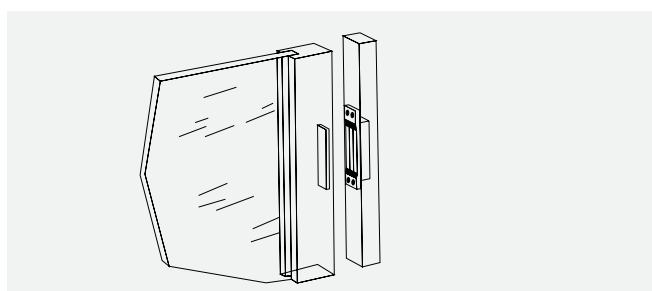

Installation Positions - Double Doors

Typical Installation

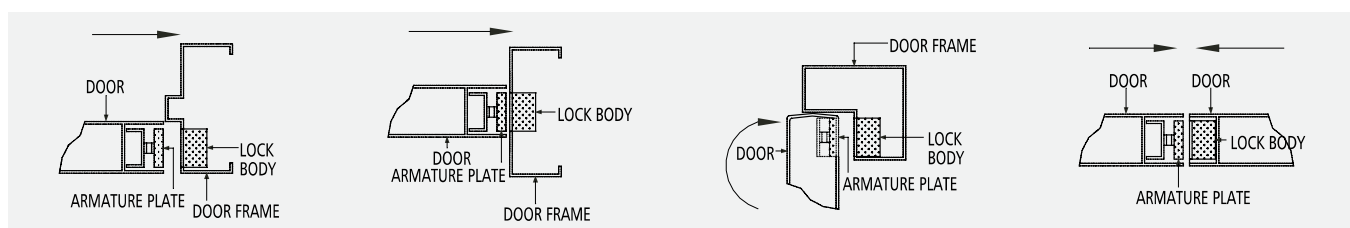

Applications

Item	Article Number	Description
KML-CCW30F	940000005664	KML-CCW30F EML 135KG MORT SGL/SLIDE/DBL

Electromagnetic Accessories



B0001
Armature plate housing for KML-6 & KML-10 (x2)
200L x 76W x 15D(mm)



B0011
Armature Plate housing for KML-2H
200L x 55W x 15D(mm)



B1001
L Adjustable bracket for KML-6 & KML10 (x2)
266L x 76W x 38D(mm)



B1002
L & Z Bracket for KML-6 & KML10 (x2)
L Bracket - 266L x 76W x 46D(mm)
Z Bracket - 185L x 63.5W x 63.5D(mm)



B1011
L Adjustable Bracket for KML-2H
250L x 48W x 30D(mm)



B1012
L & Z Bracket for KML-2H
L Bracket - 250L x 48W x 30D(mm)
Z Bracket 185L x 50W x 50D(mm)



B1022
L & Z Bracket for KML-CCW30
L Bracket - 166L x 42W x 30D(mm)
Z Bracket - 166L x 38W x 38D(mm)



U-185
U Bracket Glass Door for KML-6, KML-10 (x2) & KML-2H - Suits 10-12mm thick glass
185L x 62W x 33D(mm)

Item	Article Number	Description
B0001	9400000001495	B0001 ARMATURE PLATE HOUSING FOR KML-6
B0011	9400000001496	B0011 ARMATURE PLATE HOUSING FOR KML-2H
B1001	9400000001549	L ADJUSTABLE BRACKET FOR KML-6
B1002	9400000001550	L & Z BRACKET FOR KML-6
B1011	9400000001555	L ADJUSTABLE BRACKET FOR KML-2H
B1012	9400000001559	L & Z BRACKET FOR KML-2H
B1022	9400000001562	L & Z BRACKET FOR KML-CCW30
U-185	9400000003219	U BRACKET FOR GLASS DOOR 10-12MM THICK

RG80

Weatherproof Lock

The RG80 is the foremost high-strength lock designed for securing gates, roller doors, shipping containers and any other commercial door or entry way.

Designed with weatherproofing as one of its critical features the RG80 offers an impressive IP67 weather rating an E-coated aluminium lock body and strike for excellent corrosion resistance and a built-in heater for continued functionality in extreme cold environments.

With full monitoring outputs including tamper proof detection along with user configurable control settings, the RG80 is the perfect indoor and outdoor locking solution.



Features

- Fail safe/Fail secure
- Variable voltage 12 to 24VDC
- Low current consumption (Heater OFF)
- IP67 weather rating
- 3 user selectable control methods
- Multiple relock attempts to lock or unlock
- Built in heater for extreme cold environments
- Bolt locked & unlocked monitoring
- Door position monitoring
- Anti-tamper detection monitoring

Typical applications

- Security gates
- Roller doors
- Cold storage rooms
- Shipping containers
- Commercial doors

Specifications

Door Gap	15mm Maximum
Static strength	50'000 newtons (5000kgs)
Dynamic strength	200 Joules
Weather rating	IP67
Cycle tested	300'000 cycles
Voltage	12-24VDC
Voltage tolerance	+/-15%
Current draw	
Standby	40mA/12VDC, 30mA/24VDC
Maximum:	1.0A/12VDC, 0.5A/24VDC
Heater On (24VDC only):	2.0A/24VDC
Monitors Switches	24VDC, 025A
Operating temperature	-35°C ~ +70°C
Operating Mode	Fail Secure/Fail Secure
Material	
Lock/Strike Body	Aluminium 383
Bolt Pin	Stainless steel 304
Strike Ring	UV Stabilized ABS

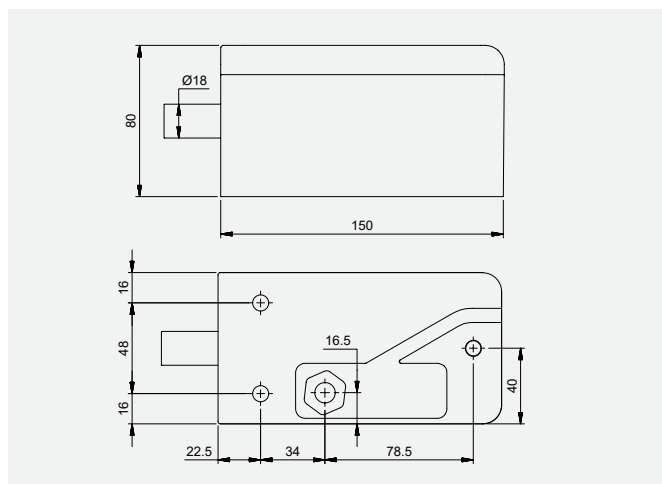

Dimensions - Lock

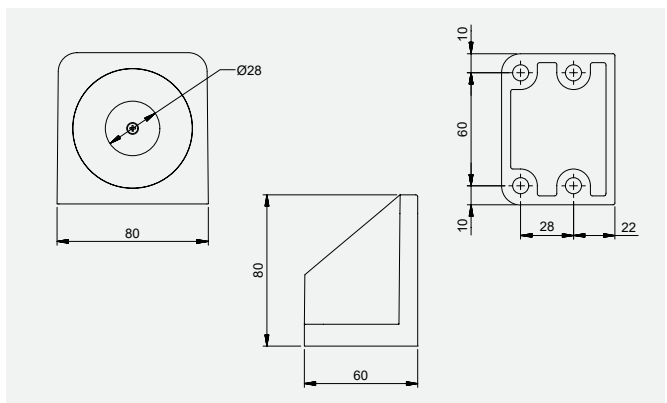

Dimensions - Strike

Item	Article Number	Description
RG80	9400000007060	RG80 LOCK & STRIKE 12-24VDC IP67 RATED
RG303A	9400000007059	STRIKE ONLY SUIT RG80

ML100

Motorised Cabinet Lock

Keep your valuables safe with the ML100 motorised cabinet lock.

The ML100 is perfect for access control on small enclosures such as lockers, drawers, drug cabinets, filing cabinets and letter boxes. The spring-release pushes the door open when activated so you can see the cabinet is unlocked and open.

In the event of power being lost from an attempted break-in or power failure, the fail-secure operation maintains its locked status keeping your valuables safe. The ML100 offers a variable 12-28VAC/DC power input and due to its motorised operation consumes minimal energy. Monitoring outputs are included as standard via door and lock status contacts.

The versatile mounting positions provide flexibility along with ease of use and installation. It is constructed of high strength polymer plastic.

Features

- Fail-secure – power to open
- 12-28VAC/DC
- Motor operated
- Built in relock time delay
- Lock and door status monitoring
- Spring door open release
- Holding force 100Kg



Specifications

Lock	60L x 60W x 22D(mm)
Strike Plate:	60L x 20W x 7D(mm)
Holding force	100kg
Voltage	12-28VAC/DC
Relock time delay	2-5 Seconds
Voltage tolerance	+/-15%
Current draw	
Holding	69mA/12VDC, 69mA/24VDC
Operating	165mA/12VDC, 165mA/24VDC
Operating Temperature	-10°C ~ +45°C
Humidity	0 ~ 95%
Operating Mode	Fail Secure
Material	Polyamide plastic
Bolt Pin	Stainless Steel, ø18mm, 35mm stroke

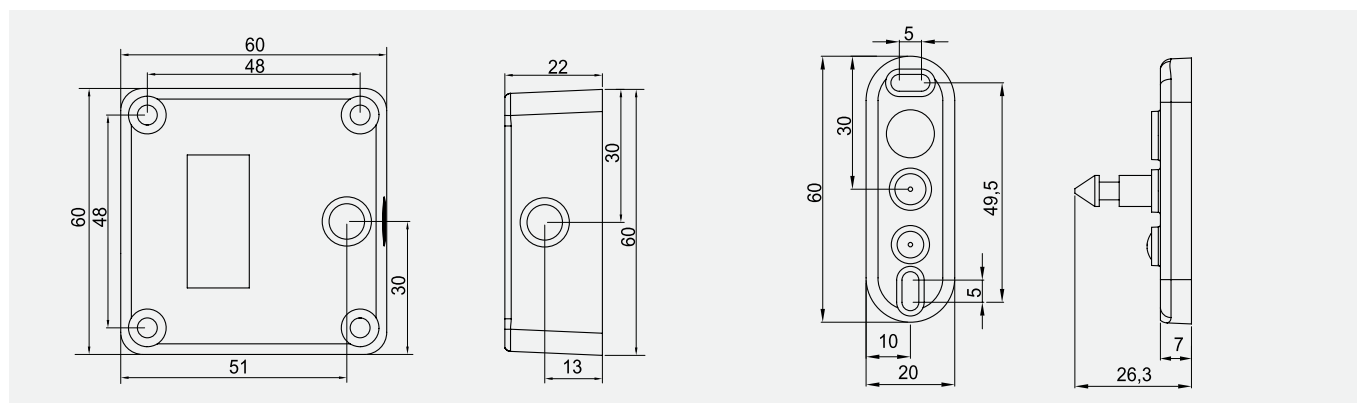

Typical Installation

Item	Article Number	Description
ML100	940000011582	ML100 CABINET LOCK 12-28VAC/DC MONITORED

KML-5000G

Electromagnetic Gate Lock

The KML-5000G is a surface mounted electromagnetic gate lock which can be used on single, double doors and gates.

It has a holding force of 540KGS and dual voltage with lock sensor. It also features a built-in voltage spike suppressor and is C-Tick, UL Listed and CE approved.

Features

- Surface mounted - single door, double swing doors, sliding doors and gates
- Built-in voltage spike suppressor
- Lock sensor (hall effect IC)
- Multiple fixing (standard) - face fix and underside
- Weather proof rating - IP65



Specifications

Lock	203L x 63W x 40D(mm)
Armature plate	185L x 61W x 16T(mm)
Holding Force	5,400N (540Kg)
Voltage	12/24VDC
Current draw	500mA/12VDC, 250mA/24VDC
Material	Stainless Steel Housing Weather proof rated IP65

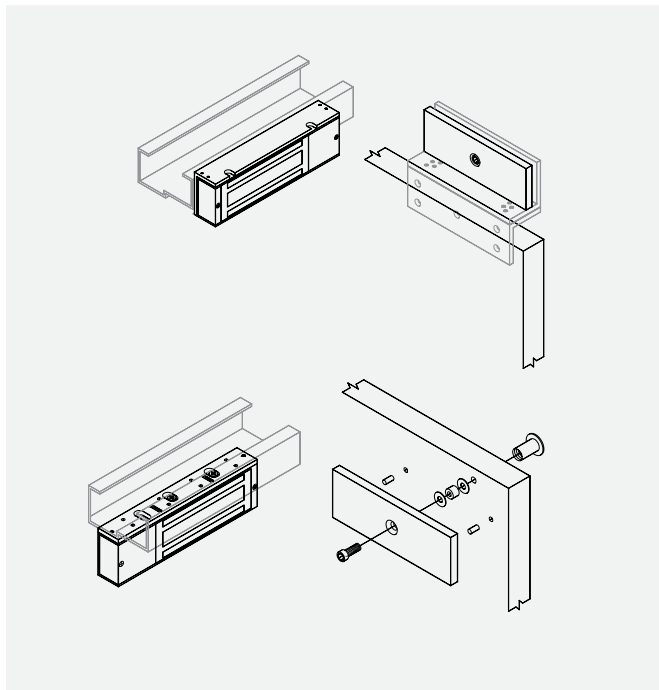

Typical Installation

Item	Article Number	Description
KML-5000G	9400000002517	KML-5000G EML 540KG GATE LOCK IP65

DL200 and DL350

Cable Transfers - Surface Mounted

The DL200 and DL350 surface mount door loop (cable transfer) are designed to allow a flexible connection to be made from the door frame to door whilst protecting the wiring from pinching or cutting.

Suitable for use in access control systems and alarms.

DL200 - Plastic Mount

Features

- Length: 40cm
- Triangle plastic sleeve
- Surface mount



DL350 - Aluminium Mount

Features

- Length: 40cm
- Square aluminium sleeve
- Surface mount

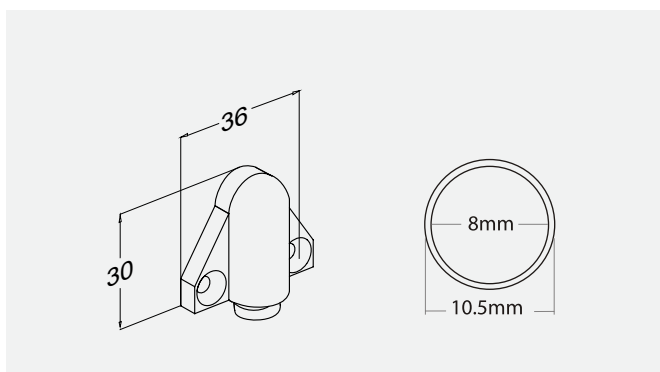

Dimensions

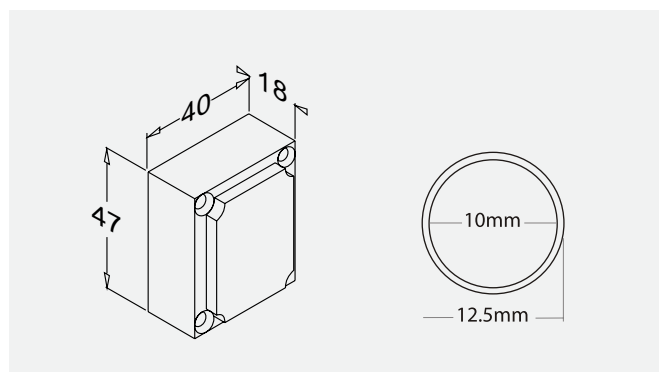

Dimensions

Item	Article Number	Description
DL200	9400000002066	CABLE TRANSFER 400MM PLASTIC MOUNT
DL350	9400000002067	CABLE TRANSFER 400MM ALUMINIUM MOUNT

DL400

Cable Transfers - Mortice Mounted

The DL400 mortice mounted door loop (cable transfer) is a convenient solution to transfer wiring from a hinged door frame to a door.

The DL400 provides an attractive solution to completely conceal the wiring when the door is closed, whilst protecting from pinching or cutting.

Suitable for use in access control systems and alarms.

Features

- Designed to ensure the unbroken transfer of cable between door and frame
- Concealed when the door is shut
- Fits timber or aluminium doors



Specifications

Dimensions	290L x 24.563W (mm)
Cable Diameter	11.8mm maximum
Door Opening	90 to 120 degree
Current draw	500mA/12VDC, 250mA/24VDC
Material	Chrome Plate Finish

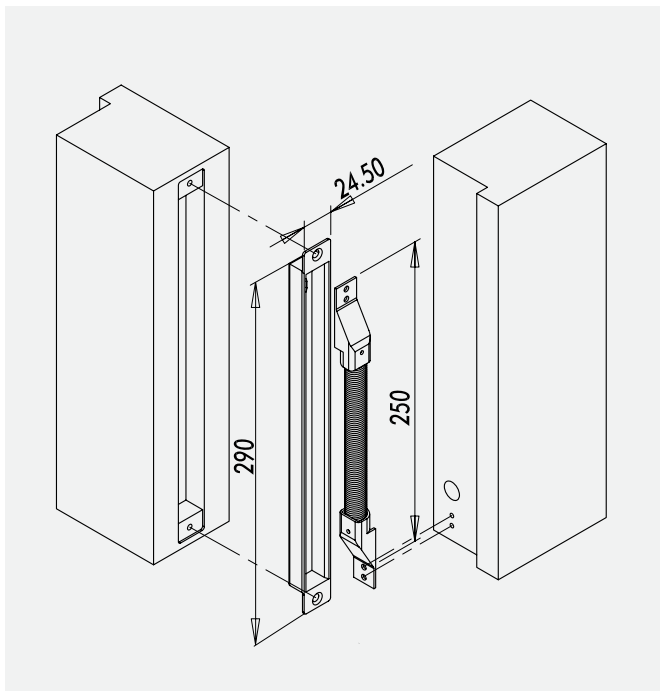

Dimensions

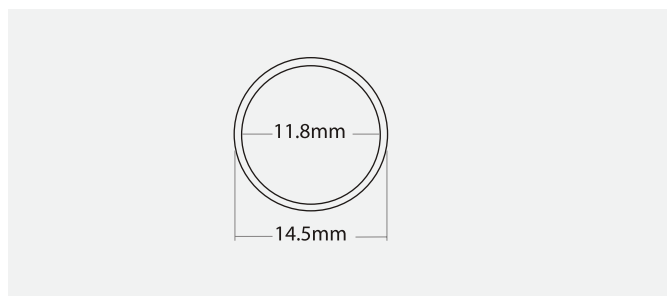

Item	Article Number	Description
DL400	940000002068	CABLE TRANSFER 290MM, MORTICE MOUNT

90 09M

Touchless Switch

The unique low-profile 90 09M touchless switch is a contactless actuator utilising capacitive proximity technology. Upon activation, the aesthetically pleasing backlight design will change colour from white to green with an optional audible beep. The touchless switch is also supported by a mechanical override function in the event of power or electronic failure.

The 90 09M also offers a selectable open time between 1-15 seconds and a typical detection zone setting of 25-50mm for different installation environments to reduce unwanted activations.

Features

- Hands free – reduces the spread of germs and bacteria
- Selectable unlock time (1-15 seconds)
- Variable voltage 12-24VDC
- Visible colour change and audible beep (optional) when activated
- Optional EXIT or HAND wave gesture

Additional functions (optional)

- Optional remote control (433MHz) feature and up to 5 remotes can be added

Convenient installation

- Fits standard size switch plate & electrical gang box
- Removeable plug in terminal block for ease of wiring

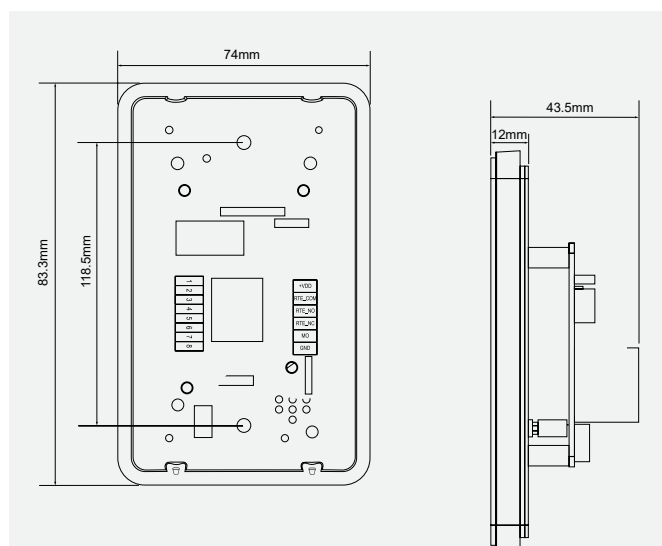

Dimensions - Lock

Item	Article Number	Description
9009MAHB	9400000011758	90 09M TOUCHLESS SWITCH ANSI HAND BLACK
9009MAXB	9400000011762	90 09M TOUCHLESS SWITCH ANSI EXIT BLACK
9009MAHW	9400000011759	90 09M TOUCHLESS SWITCH ANSI HAND WHITE
9009MAXW	9400000011763	90 09M TOUCHLESS SWITCH ANSI EXIT WHITE



Specifications

Lock	118.2L x 74.2W x 8.5H(mm)
Detection Mode	Proximity
Technology	Capacitive proximity sensor
Detection Zone	Adj. 25-50mm
Output	Dry contact (SPDT) rated @ 30VDC/1Amp
Switch mode	Momentary
Voltage	12-24VDC
Voltage tolerance	+/-10%
Current Draw	
Standby	50mA
Activated	115mA
Weather rating	Indoor
Operating temperature	-20oC ~ +60oC
Operating humidity	10%-90%
Colour	Black White
Material	PC + ABS



**Door
Hardware**



**Entrance
Systems**



**Electronic
Access & Data**



**Interior Glass
Systems**



**Lodging
Systems**



**Mechanical
Key Systems**



Safe Locks



Services

dormakaba Australia

Head Office
12-13 Dansu Court
Hallam VIC 3803
T 1800 675 411
info.au@dormakaba.com
www.dormakaba.com.au

dormakaba New Zealand

Head Office
Building P, 61-69 Patiki Road
Avondale, Auckland 1026
T: 0800 436 762
info.nz@dormakaba.com
www.dormakaba.co.nz