

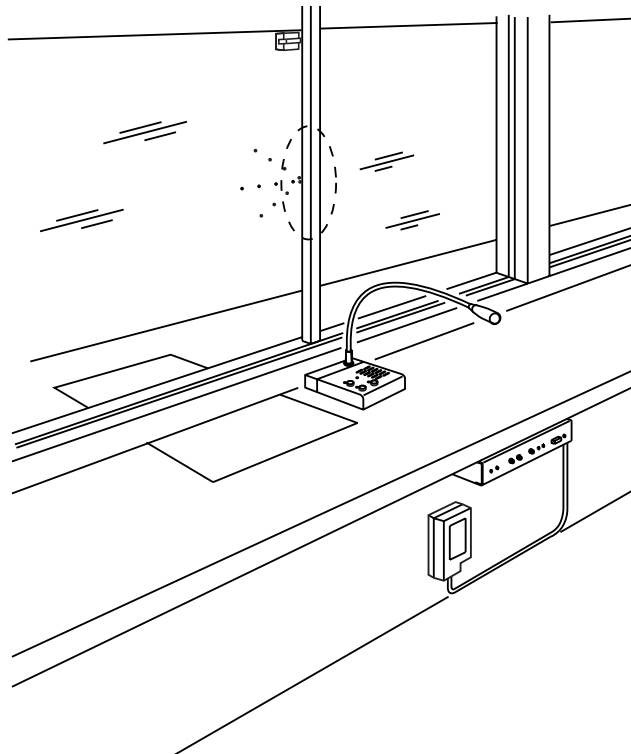

# SECURITY WINDOW INTERCOM SYSTEM

IMU-100, IAI-100, IAX-100, IME-100, ISE-100, IME-150



## PRECAUTIONS

English

- ⊘ General Prohibitions
- ⊘ Prohibitions on Dismantling the Unit
- ⊘ Prohibitions on Subjecting the Unit to Water
- ⚠ General Precautions

### ⚠ WARNING

*(Negligence could result in death or serious injury to people)*

- ⊘ 1. Do not dismantle or alter the unit as it could result in a fire or electric shock.
- ⊘ 2. Do not connect the unit with any non-specified power source. Fire or electric shock could result.
- ⊘ 3. Keep the unit away from water or any other liquid. If the unit gets wet a fire or electric shock could result.
- ⊘ 4. Do not put any metal into the unit through the openings. Fire or electric shock could result.
- ⊘ 5. Do not plug or unplug with wet hands. Electric shock could result.
- ⚠ 6. Keep AC plug away from moisture or dust. Fire could result.
- ⊘ 7. Keep AC cord from being marred or crushed. If the AC cord is fractured, fire or electric shock could result.
- ⊘ 8. Do not make the wires or DC output terminals shorted. Fire or electric shock could result.

### ⚠ CAUTION

*(Negligence could result in injury to people or damage to property)*

- ⚠ 1. Before turning on power, make sure wires are not crossed or shorted. Fire or electric shock could result.
- ⚠ 2. Mount the unit onto the wall in a place where it cannot be easily jarred or bumped by people. Injury could result.
- ⊘ 3. Do not lay out the wires or make any connections while the power supply is turned on, as it could result in an electric shock or malfunction.
- ⊘ 4. Do not install the unit where it will be subject to a large amount of vibration or shocks, as it could cause the equipment to fall over and cause an injury.
- ⊘ 5. Do not install or use the unit in any of the following places, as it could result in a fire, electric shock or malfunction.
  - \* Places in direct sunlight, or near heating equipment that varies in temperature.
  - \* Places exposed to metal particles, dust, oil or chemicals.
  - \* Places subject to moisture and humidity extremes, such as bathrooms, cellars or greenhouses.
  - \* Places where the temperature is quite low, such as inside a refrigerated area or in front of an air-conditioner.
  - \* Places directly exposed to steam or oily fumes, such as next to kitchen worktops or heat appliances.
  - \* Places exposed to noise from electric products, such as dimmer switches or inverters.
- ⚠ 6. On products with ground terminals, connect to an earth ground. Fire or malfunction could result.
- ⚠ 7. For DC powered systems, use Aiphone power supply model specified with system. If non-specified product is used, fire or malfunction could result.
- ⊘ 8. In case of electrical storms, unplug the unit from AC outlet. If not, fire or electric shock could result.
- ⊘ 9. Do not put anything on or cover the unit with cloth, etc. Fire or unit trouble could result.
- ⊘ 10. Do not have the weak currency wires pinched by windows, etc.

### GENERAL PRECAUTIONS

1. This unit is for indoor use only. Do not use outdoors.
2. In areas where broadcasting station antennas are close by, the intercom system may be affected by radio frequency interference.
3. The unit turns inoperative during power failure.
4. The unit can be damaged if dropped. Handle with care.
5. As to other manufacturer's devices, such as sensor, detectors, door releases, used with this system, comply with the Specifications and Warranty conditions manufacturers or vendors present.
6. If the unit is down or does not operate properly, unplug or turn off power switch.
7. If the phone is operated near OA equipment, Radio or TV, they interactively influence by radio frequency interference. Carefully select both locations for installation and operation.
8. Do not locate the control unit in a location with restricted access. It impedes maintenance inspection or repairs. Also, unit trouble could result.

## 1 PACKAGE CONTENTS

### 1-1

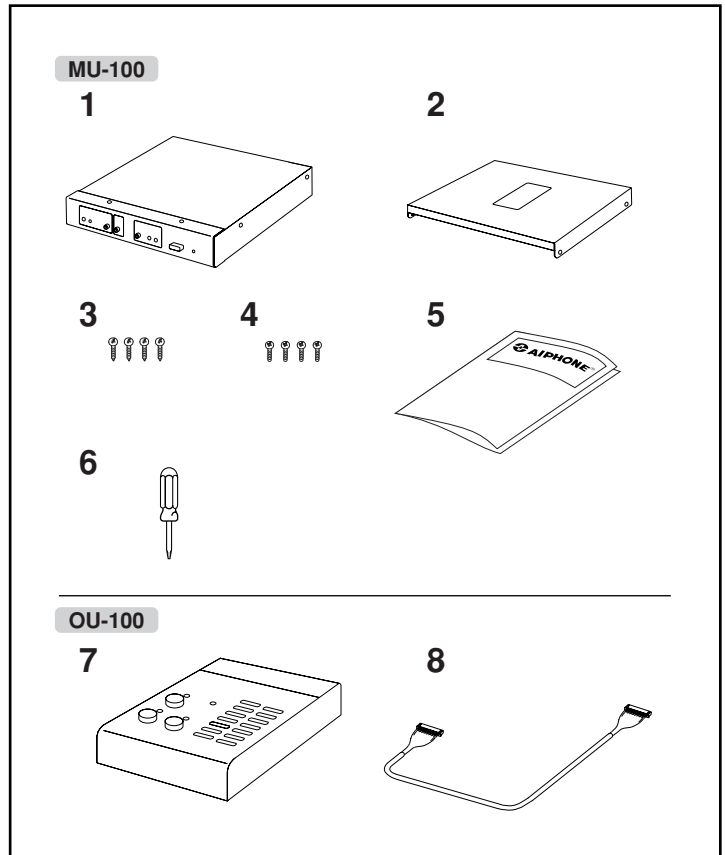

### Package contents (main kit IMU-100)

English

1. Main unit MU-100
2. Mounting bracket
3. Screws for joining the main unit to the bracket (black) (x4)
4. Counter installation screws (x4)
5. Operation manual
6. Screwdriver for setting up
7. Operation unit OU-100
8. Connection cable (2 m)

## 1-2

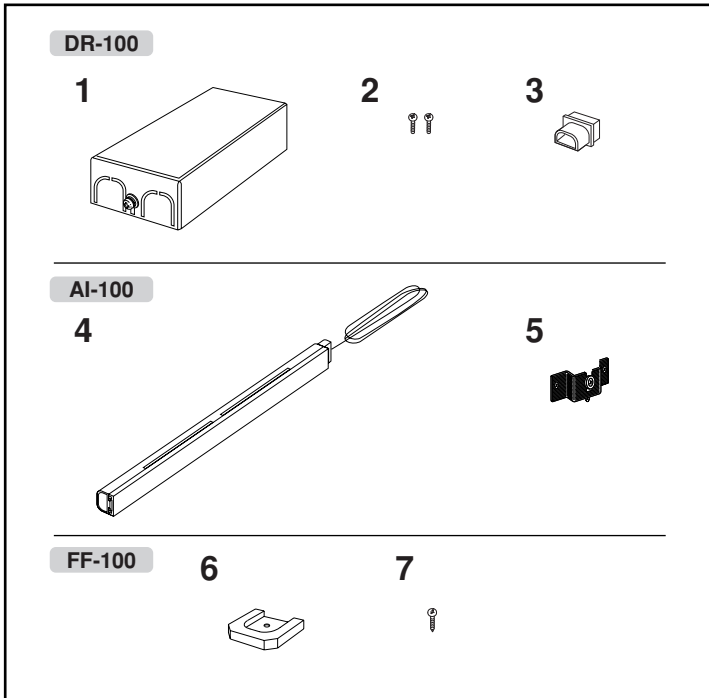

### Package contents (acoustic interface kit IAI-100) English

1. Driver unit DR-100
2. Screws
3. Rubber seal
4. Acoustic I/O tube AI-100
5. Temporary installation jig
6. Tube fixer FF-100
7. Counter installation screw

## 1-3

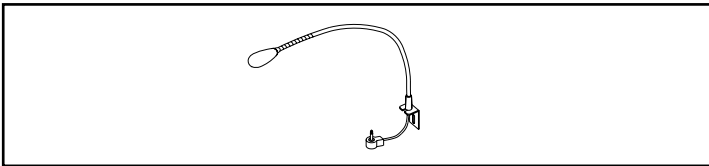

### Package contents (gooseneck microphone IME-100) English

- Gooseneck microphone IME-100

## 1-4

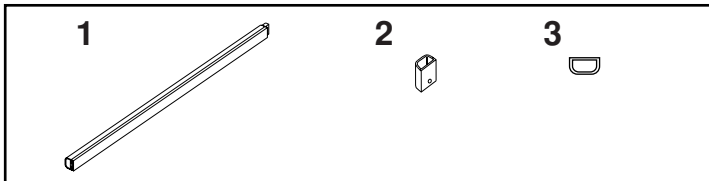

### Package contents (acoustic tube IAX-100) English

1. Acoustic tube IAX-100
2. Tube connector
3. Packing (semi-transparent)

## 1-5

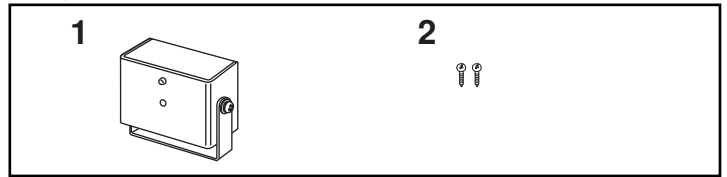

### Package contents (sensor ISE-100) English

- Optional package
1. Sensor ISE-100
  2. Screws

## 1-6

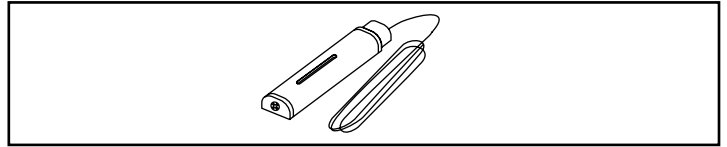

### Package contents (optional microphone IME-150) English

- Optional package
- Optional microphone IME-150

## 2 DESCRIPTION

### Description English

This security window intercom system provides a means of communication for two people conducting business on either side of a security window, such as at a bank, theatre, or law enforcement facility.

#### Features

- A new acoustic tube system is used that combines an acoustic tube speaker with a noise canceling microphone. This ensures clear sound quality with sufficient volume.
- The use of the new acoustic tube system means that the unit can be installed without having to make a hole in the barrier glass. The acoustic tube is long and thin, ensuring that the field of vision between the operator and the customer is not obstructed.
- The circuit of the noise canceling microphone is built in to the acoustic tube system, lessening the effects of ambient noise and making sure the operator accurately hears the customer.
- The sound of the customer's voice is concentrated ensuring that nothing is misheard, and the voice of the operator is detected by the VOX circuit and transmitted automatically. This means that no operations are necessary during communication, making it a smooth and user-friendly system.
- When the operator leaves the booth or does not want voices from inside to be heard outside, the system can be put into standby mode by turning off the TALK switch so that sound is not transmitted.
- A volume switch is provided that can be changed from "Lo" to "Hi" when there is an increase in ambient noise or if a customer is hard of hearing.
- Option: A sensor is available that automatically switches the system to standby mode when there are no customers (automatic operation system).
- Option: There is an in-built paging function so that customers in outside waiting rooms can be easily called. A separate paging speaker must be installed for this function.

### 3 INSTALLATION

#### 3-1

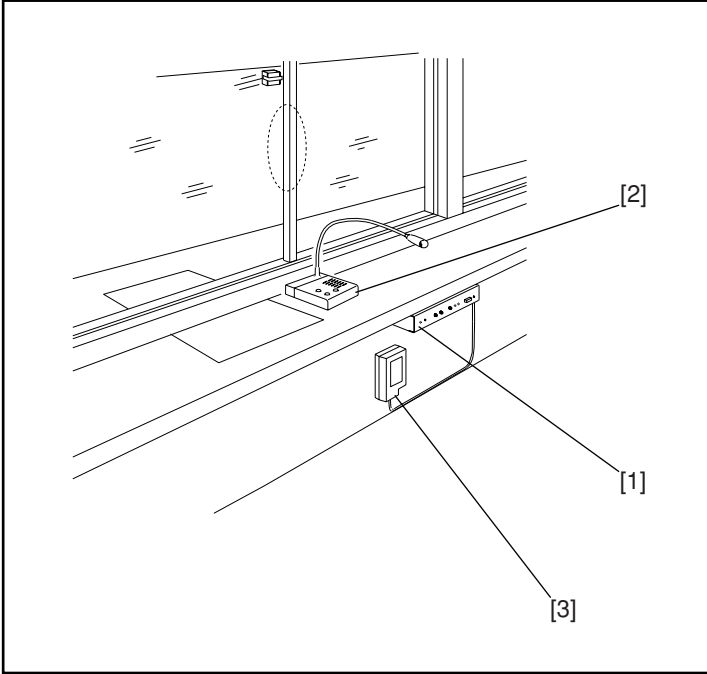

#### Operator units

English

- [1] Main unit MU-100  
Position under the desk. Can be installed with the mounting bracket provided.
  - [2] Operation unit OU-100  
Position on the left or right of the window desk, in a user-friendly location.
  - [3] Power supply adapter PS-2420UL/2420S  
Position between the AC outlet and main unit in a location where it can be easily installed.
- ⚠ Drill holes for wiring as needed before installing the units.

#### 3-2

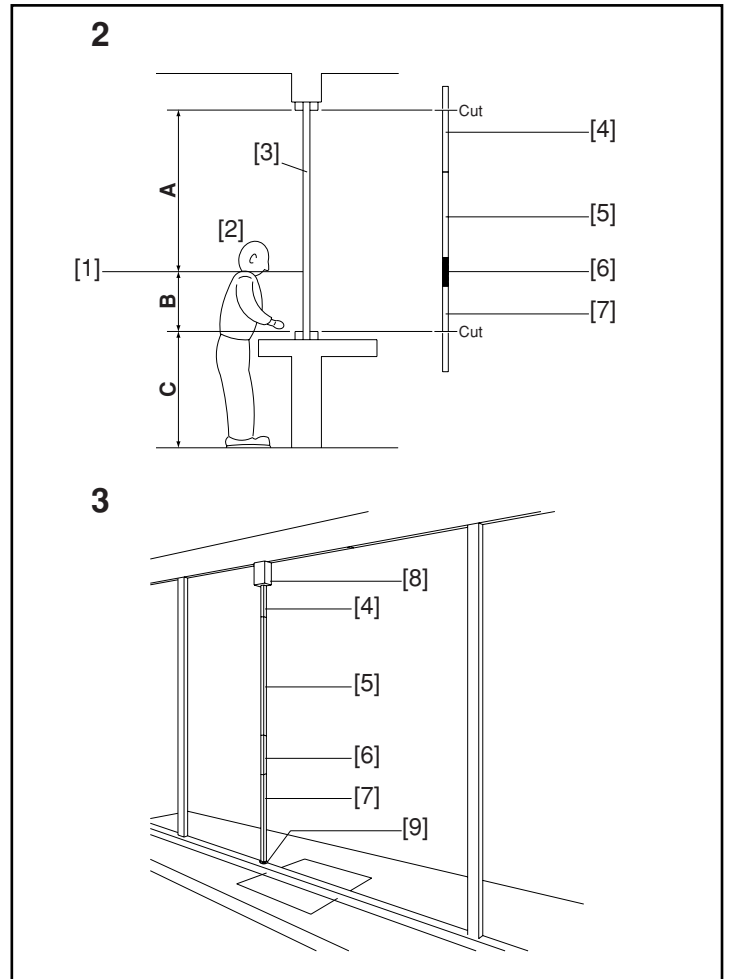

- [1] Center of acoustic I/O tube
- [2] Customer
- [3] Barrier glass
- [4] Upper acoustic tube (2)
- [5] Upper acoustic tube (1)
- [6] Acoustic I/O tube
- [7] Lower acoustic tube
- [8] Driver unit
- [9] Tube fixer

1. Estimate the average height of customers, taking into account gender and age differences. Mark on the glass the height where the average customer's head would be during a conversation with the operator. Customers usually bend down a little when they talk.
  - Recommendation: 130cm (51") above the floor
  - If voices can pass directly through the cash tray opening, this can be used for communication with customers who are children. If the window has such an opening, children can be excluded from the average height estimate.
2. Referring to the diagram, measure the vertical dimension of the barrier glass of the booth in the area where you intend to install the tubes, and decide how many acoustic tubes are necessary.
  - At least one acoustic I/O tube must be used.
  - The total length of the acoustic tube is 1m (3'3"), and it must be installed on both the upper and lower sides of the acoustic I/O tube. It is possible to cut the acoustic tube and use the pieces above and below the acoustic I/O tube.

⚠ The position measurements you have made will be used during installation, so be sure to record them.
3. Determine the position on the exterior of the barrier glass.
  - The optimum position is with the center of the acoustic I/O tube at the height of the customer's mouth, and 300mm to 400mm (12" to 16") to the right or left.
  - Install the driver unit in the position where the glass and ceiling meet (sash).
  - Install the acoustic tube vertically on either the left or right side of the customer, whichever is more appropriate.
  - Be sure to install the tube not just simply by attaching it to the glass, but also by using the screws to fix it to the ceiling at the top and the counter at the bottom.

⚠ 1. If liquid or moisture gets into the acoustic tube it could result in a malfunction, so select the installation position carefully.

⚠ 2. The sections below the driver unit (acoustic tube, acoustic I/O tube) are water-resistant. Even so, do not directly spray them with water, as it could result in a malfunction.

## 3-3

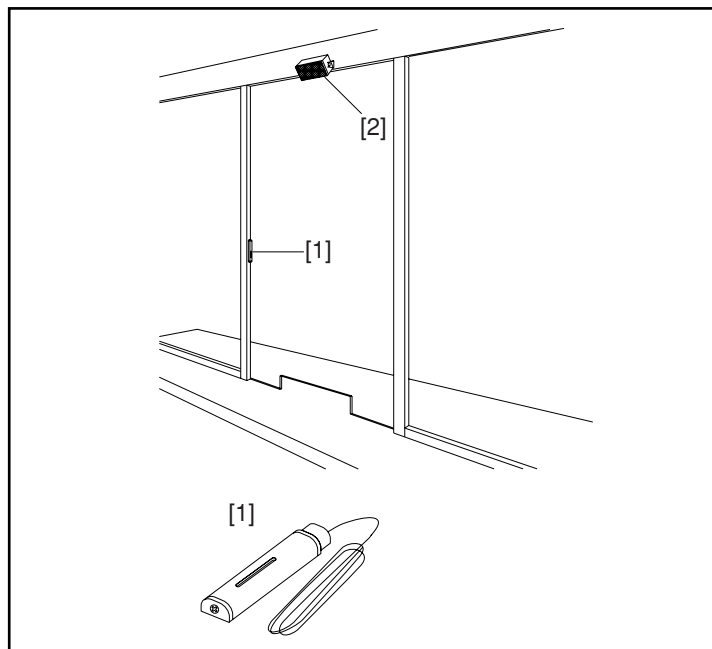

### Outer microphone/speaker

English

The system can be used with an optional microphone and external speaker if the acoustic interface kit and acoustic tube are not installed.

[1] Optional microphone IME-150

[2] External speaker

- Use one optional microphone. The optimum position is at the height of the customer's head, and 300mm to 400mm (12" to 16") to the right or left. It is recommended that the microphone be installed on the vertical mullion of the window.
  - Use one external speaker. Install above the head of the customer in a position where the sound can be clearly heard. Use a type of speaker suitable for your needs.
    - Impedance: 4 to 8  $\Omega$
    - Rated input: 3 W or more
    - Maximum input: 6 W or more
  - Lay out the wires within the mullion, or use a raceway.
- ⚠ 1. If liquid or moisture gets into the microphone it could result in a malfunction, so select the installation position carefully.
- ⚠ 2. The optional microphone is not water-resistant.

## 4 MOUNTING

### 4-1

#### Main materials and tools

English

#### 1. Main materials

##### • Double-sided tape

Select a tape suitable for your usage environment.

Recommendation: 4910 (made by 3M)

If you are using the acoustic tube system, cut a piece of tape approximately 50cm (20") longer than the total length of the tubes.

If you are using the optional microphone, cut a piece of tape approximately 10cm (4") in length.

##### • Connection cable

Use a 2-conductor shielded cable for the microphone, and an 18AWG cable for the speaker. The cables should be long enough to extend from the microphone and speaker to the main unit.

##### • Cleaning fluid

Fluid for cleaning the surface before adhesion (a fluid that will not affect the adhesive power of the double-sided tape).

#### 2. Special tools

##### • Metal saw

Use for cutting the acoustic tube.

##### • File

Use to smooth the cut surfaces of the acoustic tube.

### 4-2

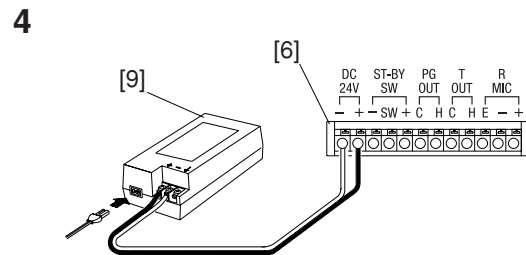
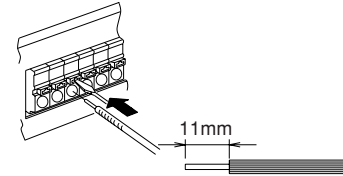
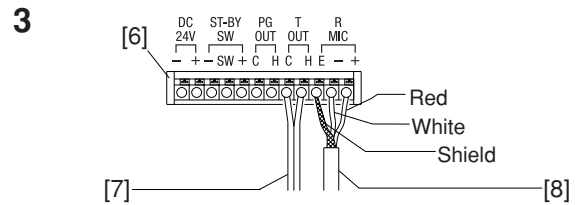
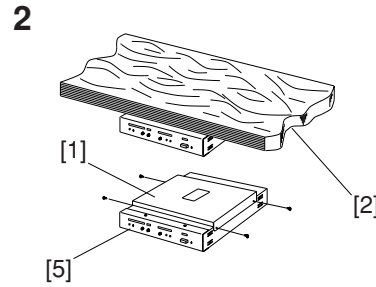
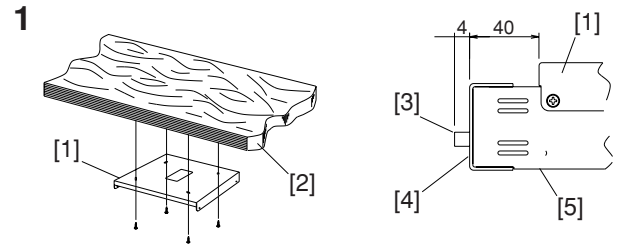

Install the main unit under the counter or desk on the operator side. The cables from the other units will be connected at a later stage by temporarily removing the main unit.

[1] Mounting bracket

[2] Counter/desk

[3] Switch

[4] Front panel

[5] Main unit

[6] Terminal block

[7] Transmit output speaker cable

[8] Receive microphone input cable

[9] Power supply adapter

1. Install the mounting bracket with the 4 screws provided, in the position where the main unit will be installed.

⚠ Install in a safe position so that the knobs do not project out from under the counter.

2. Position the main unit on the mounting bracket (temporarily tighten with the 4 screws provided), and check whether the knobs or any other part projects out.

3. Connect the receive input microphone cable that comes from the acoustic I/O tube (or optional microphone), and the transmit output speaker cable that comes from the driver unit (or outer speaker) to the main unit terminal block.

- Connect the receive input microphone cable that comes from the acoustic I/O tube (or optional microphone) to R MIC [+ – E] of the main unit terminal block. Insert the hot (red) wire of the receive microphone into the + terminal, the ground (white) wire into the – terminal, and the shield wire into the E terminal.

- Connect the transmit output speaker cable that comes from the driver unit (or outer speaker) to T OUT [H C] of the main unit terminal block. Insert the hot (black) wire of the transmit speaker into the + terminal, the ground (white) wire into the – terminal.

⚠ 1. Be sure not to short the power supply cable and speaker cable, as it could cause a speaker malfunction.

⚠ 2. Cut the cable in advance so that it is long enough to reach the installation position of the main unit.

4. Position the power supply adapter under the counter or desk, in a safe location between the power supply socket and main unit. Connect the + terminal of the power supply adapter to the DC24V + terminal of the main unit, and the – terminal of the power supply adapter to the DC24V – terminal of main unit.

⚠ 3. On power supply, take FG (⊥) terminal to an earth ground.

⚠ 4. Do not turn on the power supply adapter until all of the installation work has been completed.

⚠ 5. Do not install in a location exposed to heat or water, and also avoid locations where excessive amounts of dust accumulate.

## 4-3

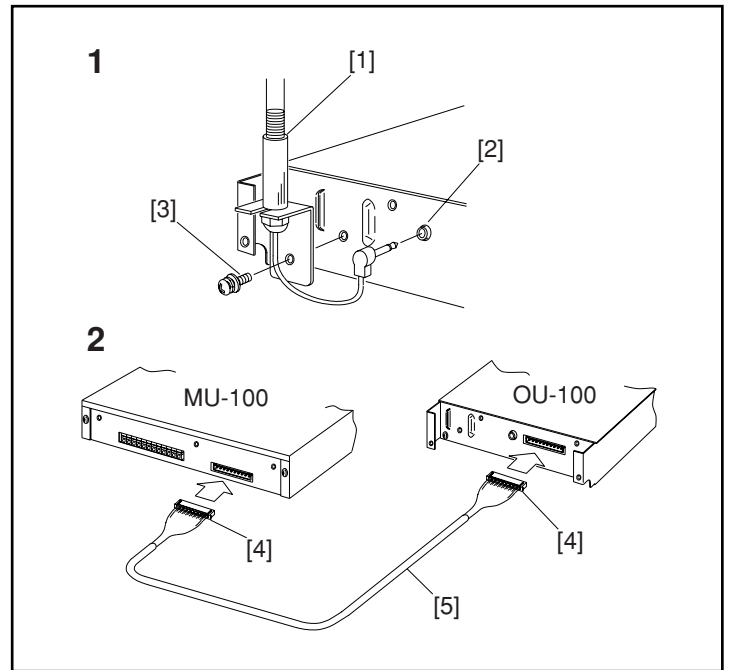

### Operation unit

### English

Position the operation unit on the counter or desk on the operator side. Select a location where operation will be easy, and check that the operation cable provided reaches the main unit.

[1] Gooseneck microphone

[2] Microphone jack

[3] Screw w/washer

[4] Connector

[5] Connection cord

1. When using the gooseneck microphone for transmission, install the gooseneck microphone before making the connections.

Install by removing the 2 screws on the rear of the operation unit and removing the rear cover.

A headset can also be used. Use a type of headset suitable for your needs.

Ø3.5 plug

Impedance: 32 Ω

Rated input: 40 mW or more

Maximum input: 100 mW or more

⚠ Only mono type headsets can be used.

2. Connect to the main unit.

⚠ 1. If you are going to make a hole in the desk for the connection cable, make sure that it is big enough for the connector at the end of the cable to pass through.

⚠ 2. If a raceway is used on the desk to manage the wiring, be sure to select a route that does not interfere with operation.

⚠ 3. When inserting or removing the connector, hold the connector housing and align the polarity. If excessive force is applied to the wires, they could break or pull out of the connector, so be especially careful during this operation.

## 4-4

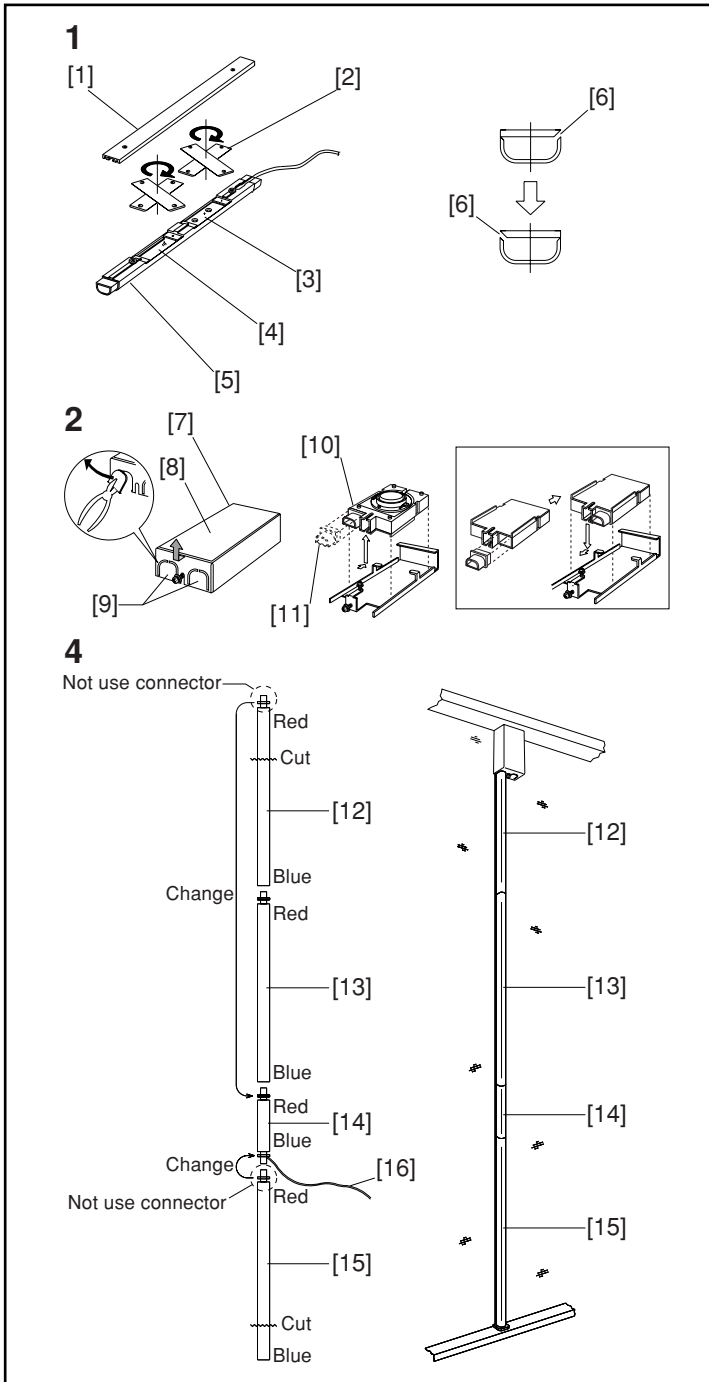

### Installation preparations for the acoustic interface English

- [1] Fixing base
- [2] Slit plate
- [3] Microphone
- [4] Acoustic output
- [5] Acoustic tube main unit
- [6] Sound I/O opening
- [7] Driver unit
- [8] Cover
- [9] Acoustic tube holes
- [10] Driver main unit
- [11] Rubber seal
- [12] Upper acoustic tube (2)
- [13] Upper acoustic tube (1)
- [14] Acoustic I/O tube
- [15] Lower acoustic tube
- [16] Microphone cord

1. When the installation position is on the left as seen from the customer side, the acoustic I/O tube can be installed unchanged from its shipped configuration. When installing it on the right, while referring to the diagram, reverse the left/right direction of both slit plates of the acoustic I/O tube so that the direction of the sound I/O opening (slit) is reversed.
2. Open the driver unit cover, and remove from inside the driver main unit. Attach the chassis to the glass, and then reinstall the driver main unit and cover. The acoustic tube can also be connected on the right side. In this case, install the driver main unit on the reverse side. Use metal cutters to cut the joints on the side where you wish to make the hole.
  - ⚠ Do not forcibly rip with pliers as it could deform the surrounding area.
3. Clean the location where the acoustic tube will be installed and the surrounding glass with standard cleaning fluid.
  - ⚠ Some types of barrier glass are made of plastic, so do not use a detergent that could damage the plastic. Also make sure it will not affect the surrounding sealant.
4. Referring to the diagram, draw a guideline on the glass from the top to the bottom to make sure that the acoustic tube is attached vertically.
  - ⚠ 1. Upper and lower sections are connected together to assemble the acoustic interface, so it is important that it is exactly vertical.
  - ⚠ 2. Do not change the position measurements because it could result in the length of the acoustic tube being insufficient.

## 4-5

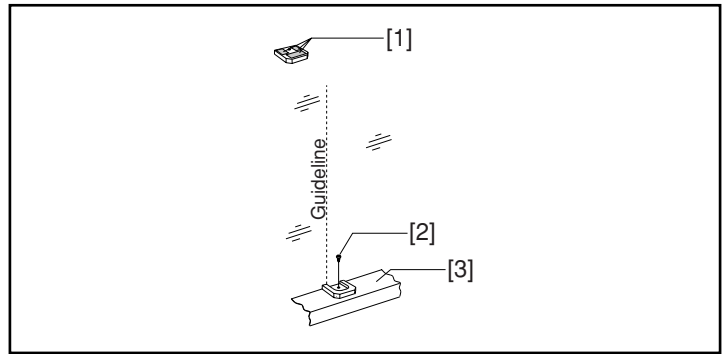

### Installation of the acoustic interface (tube fixer) English

- [1] Double-sided tape
  - [2] Set screw
  - [3] Counter sash, etc.
1. The tube fixer secures the bottom of the lower acoustic tube. Secure on the customer side of the counter with the screw provided and double-sided tape.
  2. Temporarily insert the acoustic tube, align the position with the guideline, and make a pilot hole in the counter.
  3. When deciding the position, it is necessary to take into account the extra thickness caused by the double-sided tape on the tube fixer and acoustic tube. In addition, the 2mm thickness of the tube fixer itself must be taken into account.
  4. When the position is determined, attach to the counter with the double-sided tape, and then secure with the set screw.



## 4-6

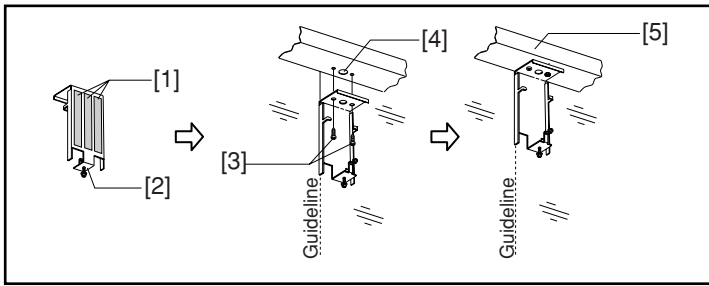

### Installation of the acoustic interface (driver unit) English

- [1] Double-sided tape
- [2] Chassis
- [3] Set screws
- [4] Cable hole
- [5] Ceiling sash, etc.

1. The driver unit is connected to the top of the upper acoustic tube. Use the screws provided and double-sided tape to secure the chassis to the position where the glass meets the ceiling.
  2. Align the position with the guideline, and make a pilot hole in the ceiling. When deciding the position, it is necessary to take into account the extra thickness caused by the double-sided tape.
  3. When the position is determined, attach double-sided tape to the glass (first attach double-sided tape to the bottom outer surface of the chassis), and then secure to the ceiling with the screws provided.
- ⚠ Make the cable hole in the ceiling for the speaker cable and microphone cable at the same time as making the screw holes.

## 4-7

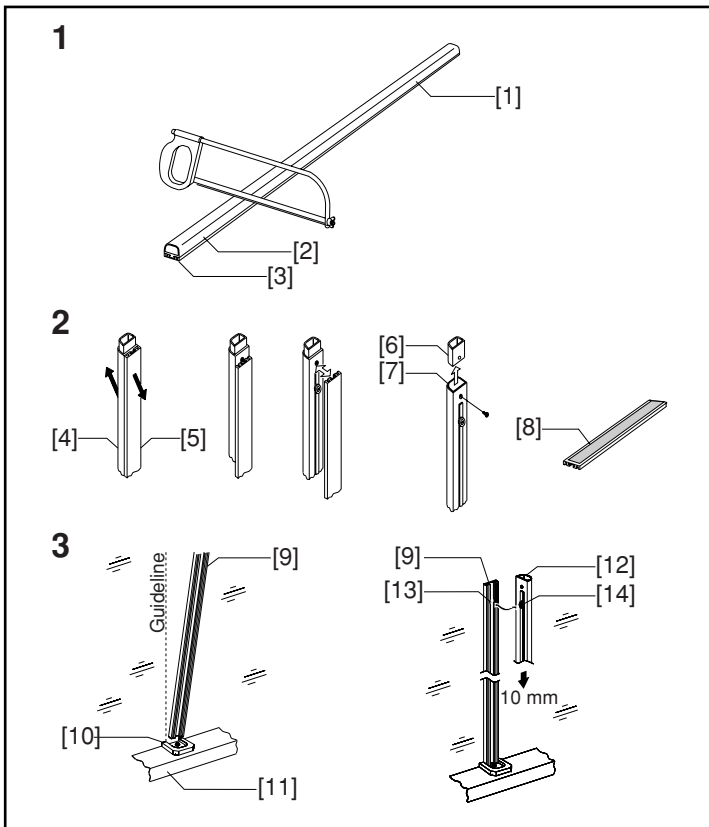

### Installation of the acoustic interface (lower acoustic tube) English

Generally, it is likely that only one acoustic tube (1 m) will be used for the lower acoustic tube. When using 2 or 3 tubes, refer to the items in "4-9 Installation of the acoustic interface (upper acoustic tube)" before installation.

- [1] Used side (red label side)
- [2] Discarded side (blue label side)
- [3] Blue label

- [4] Main unit
- [5] Base
- [6] Tube connector
- [7] Red label
- [8] Double-sided tape
- [9] Fixing base of the lower acoustic tube
- [10] Tube fixer
- [11] Counter sash, etc.
- [12] Acoustic tube main unit
- [13] Connection groove
- [14] Connection ridge

- Temporarily insert the red label side of the acoustic tube into the connector on the bottom of the acoustic I/O tube, and align with the installation surface. Keeping the acoustic I/O tube at the height that was decided earlier, decide where the acoustic tube should be cut on the bottom. The ideal cutting position would be at a length where the bottom of the acoustic tube makes contact with the bottom of the tube fixer when the tube is inserted into the fixer.
  - Remove the tube connector that is installed on to the acoustic tube. Move the packing installed on the tube connector to the bottom of the acoustic I/O tube (microphone cord side).
  - When using only one acoustic tube on the lower side (1 m or less), the removed tube connector is not used. When using 2 or more tubes, the tube connector is used together with the packing in the connection.
  - Cut the acoustic tube at the appropriate length. When cutting the lower acoustic tube, make sure that the side that is discarded is the blue label side. Do not cut the red label side because it is the tube connection side.
  - Cut while the acoustic tube main unit and fixing base are correctly assembled together. This is easier if tape is used to secure both sides so they are not misaligned.
  - Cut carefully so that the cut surface is perpendicular to the long side of the tube.
  - After cutting, use a file or sandpaper to smooth the cut surface of the acoustic tube main unit and fixing base so they can both be inserted into the tube fixer.
- ⚠ 1. There are screws for setting the fixing base and acoustic tube main unit at 5 cm, 35 cm, 65 cm and 95 cm from the blue label. Make sure the cutting position is not the same as these fixing positions.
- ⚠ 2. When cutting one acoustic tube and using it above and below the acoustic I/O tube, use the blue label side of the acoustic tube as the lower acoustic tube. Use the red label side of the acoustic tube as the upper acoustic tube. The tube connector is not used, but packing is used at the connection of the upper acoustic tube and acoustic I/O tube.

### 2. Attachment

- Pull out the acoustic tube main unit and fixing base, and attach double-sided tape to the outer surface (flat surface) of the fixing base.
  - After attaching the double-sided tape to the fixing base, position the tube so that the red label is on the upper side, and insert the bottom into the tube fixer. Align with the guideline while the tube makes contact with the bottom of the tube fixer, and attach to the glass.
- ⚠ 3. The double-sided tape can be seen from the operator side, so when attaching make sure it does not protrude from the edges and is not bent.
- ⚠ 4. The acoustic tube main unit can be pulled out by sliding it up 10mm from the fixing base.

### 3. Check

- After attachment, insert by aligning the connection ridge of the acoustic tube main unit (with the red label on the upper side) and the connection groove of the fixing base. Try to secure while pushing downwards (the slide distance is approximately 10mm). Check that the tube can be inserted to the bottom of the tube fixer and that it can be fully secured. After checking, remove the acoustic tube main unit.
- ⚠ Do not apply excessive force, as the adhesive power of the double-sided tape will not yet have reached its full strength.

## 4-8

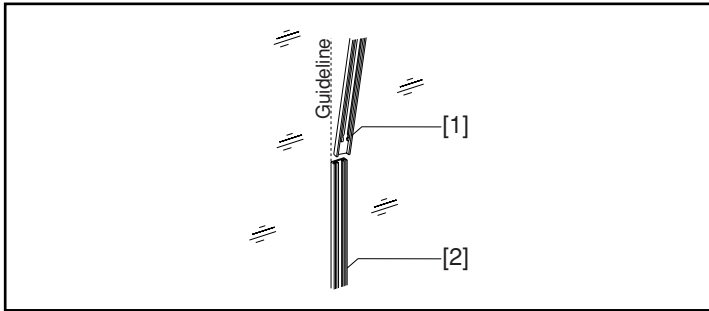

### Installation of the acoustic interface (acoustic I/O tube) English

[1] Fixing base of the acoustic I/O tube

[2] Fixing base of the lower acoustic tube

1. Remove the fixing base from the acoustic I/O tube main unit.
2. Attach double-sided tape to this fixing base. With the red label on the upper side, position the bottom of the fixing base of the acoustic I/O tube so that it makes contact with the top of the fixing base of the lower acoustic tube, which is already attached to the glass. Attach the fixing base of the acoustic I/O tube to the glass by aligning it with the guideline and making sure there is no gap between it and the lower fixing base, and that there is no misalignment to the left or right.

⚠ The acoustic tubes should be fully connected, so it is important that the upper and lower fixing bases are installed with no misalignment to the left or right.

3. After attachment, insert while aligning the connection ridge of the acoustic I/O tube main unit and the connection groove of the fixing base. Try to fix while pushing downwards (the slide distance is approximately 10mm). Push down to the boundary of the upper and lower fixing bases, and check that it can be fully fixed. After checking, remove the acoustic I/O tube main unit.

⚠ Do not apply excessive force, as the adhesive power of the double-sided tape will not yet have reached its full strength.

## 4-9

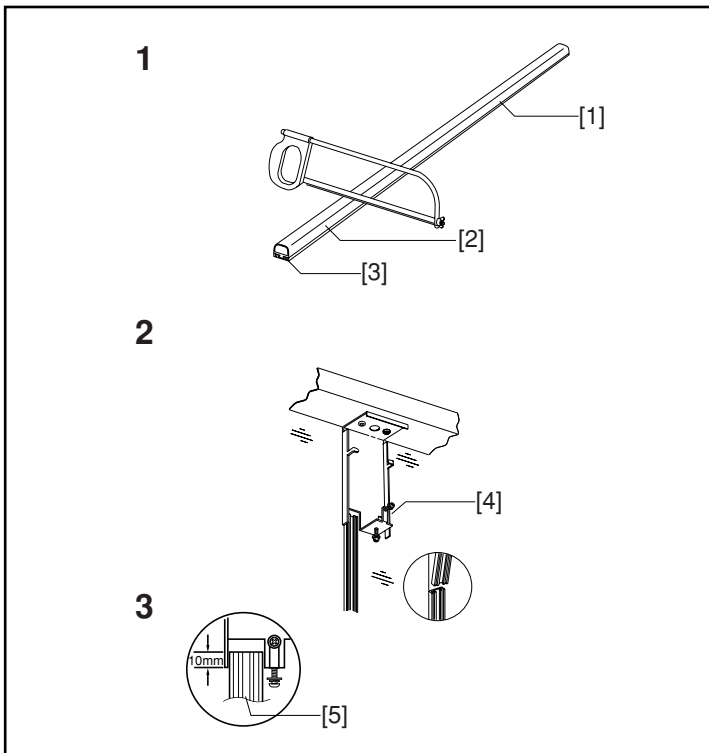

### Installation of the acoustic interface (upper acoustic tube) English

[1] Used side (blue label side)

[2] Discarded side (red label side)

[3] Red label

[4] Driver unit chassis

[5] Fixing base

#### 1. Measurements and cutting

- Align the position of the top of the fixing base of the acoustic I/O tube that has already been installed with the position of the blue label side of the upper acoustic tube. Decide the cutting position by aligning the fixing base with the position shown by the driver unit tube top position diagram. The tube top position diagram shows the ideal position for the top of the tube after cutting.
- When cutting the upper acoustic tube, make sure that the side that is discarded is the red label side. Do not cut the blue label side because it is the tube connection side (the end that should be cut is opposite for the upper and lower tubes).
- Install the removed packing on the top of the acoustic I/O tube.
- When using only one acoustic tube on the upper side (1 m or less), the removed tube connector is not used. When using 2 or more tubes, the tube connector and packing (of the 1 m acoustic tube that is not cut) are used unchanged.
- After cutting, use a file or sandpaper to smooth the ends of the acoustic tube main unit and fixing base. After the cut surface is completely smooth, it is connected to the driver unit with the rubber seal.

⚠ The red label side of the upper acoustic tube is discarded.

#### 2. Attachment

- Attach double-sided tape to the outer surface (flat surface) of the fixing base.
- Attach double-sided tape to the fixing base of the upper acoustic tube. With the blue label on the lower side, position so that it makes contact with the top of the fixing base of the acoustic I/O tube that has already been installed. Attach to the glass by making sure there is no misalignment to the left or right and that it is aligned with the vertical guideline. If the top is aligned with driver unit chassis in the tube top position diagram shown on this page, then the position is correct.
- After attachment, insert the acoustic tube main unit into the fixing base, and check the fixing condition while pushing it downwards (the slide distance is approximately 10 mm). After checking, remove the acoustic tube main unit. The acoustic tube main unit could slip and fall when checking the fixing condition, so do not let go of it.

⚠ 1. The double-sided tape can be seen from the operator side, so when attaching make sure it does not protrude from the edges and is not bent.

⚠ 2. The acoustic tubes should be fully connected, so it is important that the upper and lower fixing bases are installed with no misalignment to the left or right.

⚠ 3. Do not apply excessive force, as the adhesive power of the double-sided tape will not yet have reached its full strength.

#### 3. Tube top position diagram

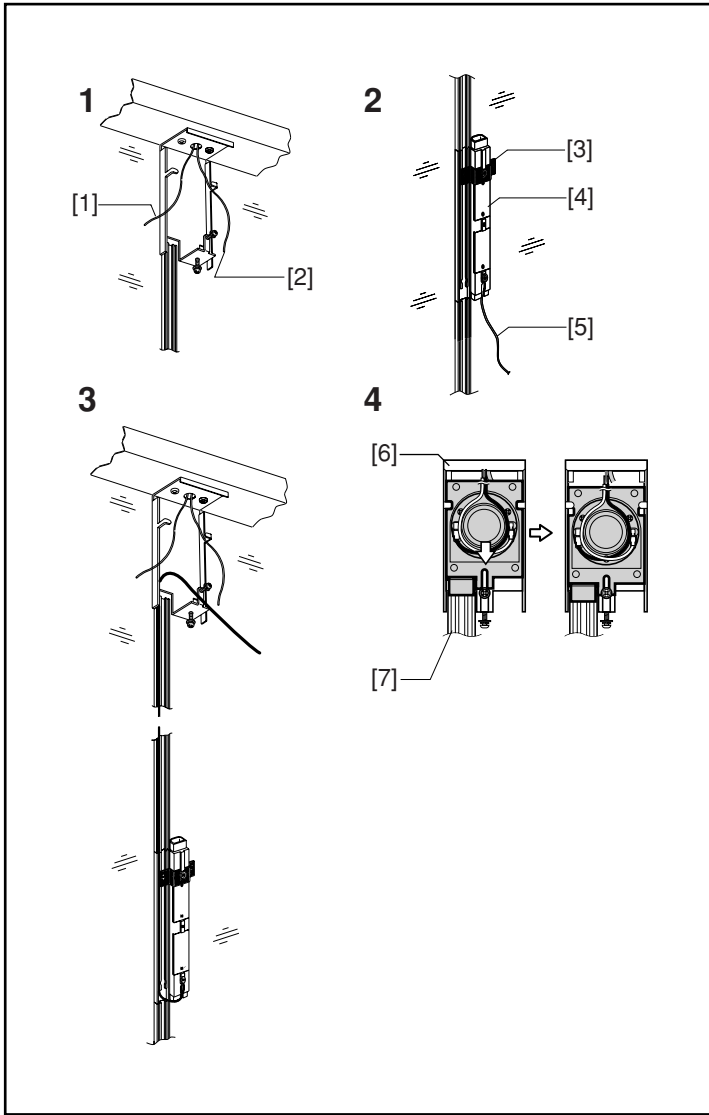

[1] Speaker cable from main unit

[2] Microphone cable from main unit

[3] Temporary installation jig

[4] Acoustic I/O tube main unit

[5] Microphone cord

[6] Chassis

[7] Cord groove

1. Pull the transmit output speaker cable and receive microphone input cable that come from the main unit on the operator side through the chassis cable hole in the driver main unit that is fixed to the glass. Cut the cables that have been pulled through at a length of approximately 20cm (3/4").
2. Use the jig to temporarily install the main unit of the acoustic I/O tube in the fixing base groove at the specified position.
  - ⚠ When installing the fixing base in the vicinity of the architectural sash, temporarily install the acoustic I/O tube on the side opposite to the architectural sash.
3. As shown in the diagram, while inserting the microphone cord that protrudes from the bottom of the temporarily installed acoustic I/O tube main unit upward into the cord groove of the fixing base, position the cable until it is in the center of the driver unit chassis. Cut the fixed cord so there is an excess length of approximately 30cm (1-1/4").
  - ⚠ Use the cord groove on the far side from the side where the acoustic I/O tube is temporarily installed. If the groove on the far side is used then the cord will fit smoothly when the acoustic I/O tube is fixed into the fixing base.
4. Return the removed driver main unit to the original position on the chassis, put into the highest slide position, and lightly fix with the specified screw. Lay out the microphone cord in the space between the chassis and the driver main unit.
  - ⚠ Pull the cables towards the upper side of the driver (ceiling side) when returning the driver main unit.

# 4-11

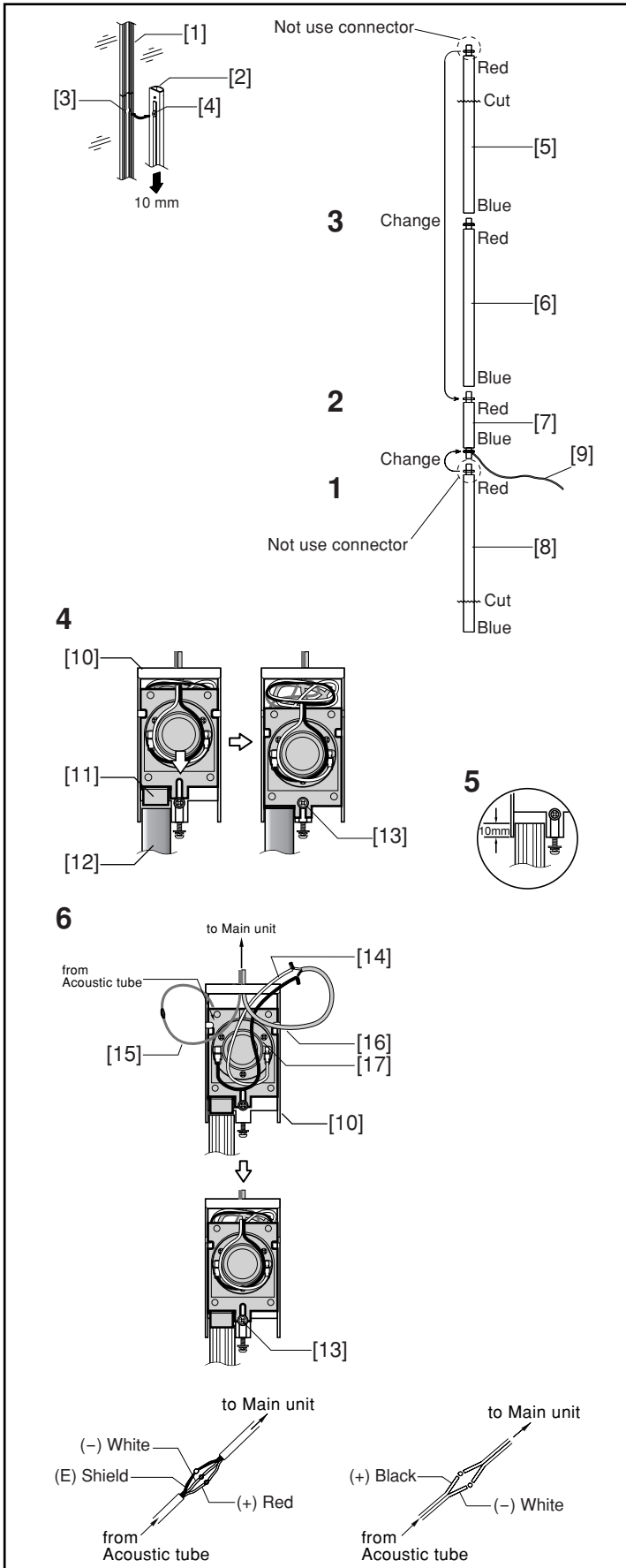

**Fixing of acoustic interface** English

- [1] Fixing base
- [2] Acoustic tube main unit
- [3] Connection groove

- [4] Connection ridge
- [5] Upper acoustic tube (2)
- [6] Upper acoustic tube (1)
- [7] Acoustic I/O tube
- [8] Lower acoustic tube
- [9] Microphone cord
- [10] Chassis
- [11] Rubber seal
- [12] Acoustic tube
- [13] Set screw
- [14] Lead cable (driver unit)
- [15] Microphone cable
- [16] Speaker cable
- [17] Driver main unit

1. Position the red label side of the lower acoustic tube on the upper side, insert while aligning the connection ridge of the tube main unit with the connection groove of the fixing base, and secure while pushing downwards (the slide distance is approximately 10mm). Fully secure by inserting to the bottom of the tube fixer.
  - ⚠ When cutting one acoustic tube and using it on the upper and lower sides of the acoustic I/O tube, install packing between the acoustic I/O tube and the upper acoustic tube.
2. Remove the temporary installation jig from the main unit of the acoustic I/O tube. While storing the microphone cord that protrudes from the lower side of the main unit into the cord space of the fixing base, insert by aligning the connection ridge of the main unit with the connection groove of the fixing base, and while pushing the tube connector into the lower acoustic tube, push downwards and secure (the slide distance is approximately 10mm).
3. Position the blue label side of the upper acoustic tube on the lower side, insert while aligning the connection ridge of the main unit and the connection groove of the fixing base, and while pushing into the acoustic I/O tube connector, push downwards and fix (the slide distance is approximately 10 mm). The top should be near to the position inside the driver main unit shown by the tube top position diagram.
  - ⚠ Do not damage the rubber seal of the driver main unit.
4. Further loosen the set screw that is lightly fixed to the driver main unit so that the driver main unit can slide. While pulling down the driver main unit, insert the rubber seal into the hole on the main unit of the acoustic tube, being careful not to damage it. When the rubber seal is fully inserted, further pull down the driver main unit until the rubber seal produces a hermetically sealed effect, and at this point fully tighten the set screw of the driver main unit. Fix the removed driver unit cover.
  - When pulling down the driver main unit so that the end of the rubber seal makes contact with the tube main unit, it helps if the rubber seal is moved a little to make it easier to access the hole in the tube main unit.
5. Tube top position diagram
6. Splice the cables.
  - Speaker cable: Splice the input cable that comes from the driver main unit with the transmit output speaker cable that comes from the main unit on the operator side, which was previously pulled through the cable hole in the ceiling.
  - Microphone cable: Splice the microphone input cable that comes out from the top of the acoustic I/O tube with the receive microphone input cable that comes from the main unit on the operator side, which was previously pulled through the cable hole in the ceiling.
  - ⚠ 1. Use a splicing method where the cables can be insulated. Insulation crimping is recommended.
  - ⚠ 2. When putting the cover on and completing the work, the cables are stored inside the box, so cut the cables to the minimum required length.
  - ⚠ 3. Be sure to splice the cables with the correct polarity.

## 4-12

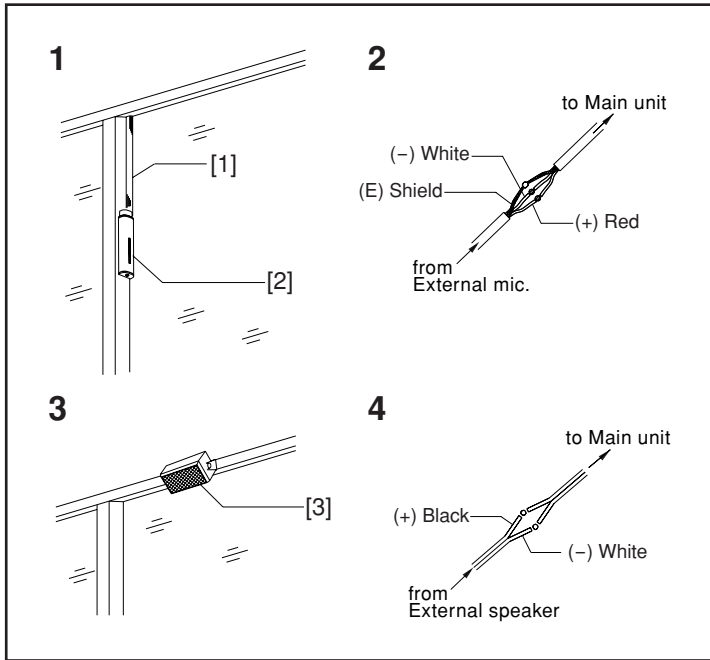

### Outer microphone/speaker

English

[1] Raceway

[2] Optional microphone

[3] Outer speaker

1. Attach the optional microphone with double-sided tape along the architectural sash. Clean the surface before attaching. Use a strong industrial double-sided tape that can attach aluminum and glass.

- Examine the wiring route in advance and determine the best layout. The appropriate position is at the height of the customer's head, and approximately 300mm to 400mm (12-16") to the right or left.

2. Splice the 2-conductor shielded cable from the optional microphone with the 2-conductor shielded cable from the main unit.

3. The outer speaker is purchased separately. For installation, follow the instructions provided with your speaker.

- The speaker should be above the customer's head. Select a suitable wiring route and determine the installation position.

4. Splice the cable from the outer speaker with the cable from the main unit.

⚠ 1. Insulate the spliced wires.

⚠ 2. Lay out the wires within the sash, or use a raceway.

⚠ 3. Be sure to splice the cables with the correct polarity.

⚠ 4. The optional microphone is not weather resistant.

## 4-13

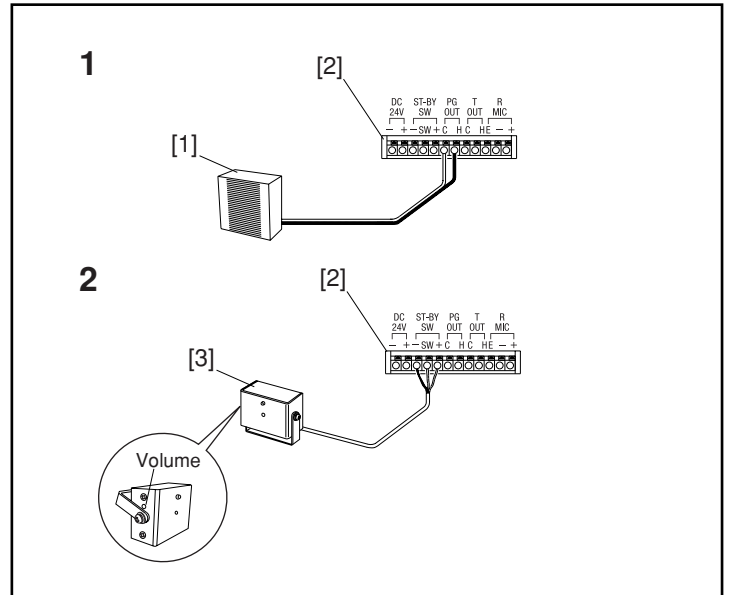

### Options

English

[1] Paging speaker

[2] Terminal block

[3] Sensor ISE-100

1. Use the instructions provided with the product when installing the paging speakers. There are many types of speakers available, such as wall speakers, ceiling speakers and horn speakers. Select the type most suitable for your paging broadcast area and your needs.

Impedance: 4 to 8 Ω

Rated input: 3 W or more

Maximum input: 6 W or more

⚠ Be sure not to short the speaker cable and the power supply cable (24V), as it could cause a speaker malfunction.

2. Install the sensor under the counter on the customer side or on the upper section of the wall with the 2 screws provided. There are screw holes in the handle of the sensor. Insert the sensor output cable (2-conductor shielded cable) into the STBY [+ SW -] terminal of the main unit terminal block, making sure that the polarity is correct.

⚠ 1. Install the sensor in a position where the customer will be sure to enter the detection area: approximately 2m, 6'6".

⚠ 2. The initial sensitivity setting for the sensor is maximum. Turn the sensitivity volume knob counterclockwise to reduce the sensitivity. The sensor is operating if the LED (green) on the sensor main unit display is illuminated. After an object stops being detected, it takes about 10 seconds for the sensor to turn off.

⚠ 3. If the lens of the sensor is dirty or dusty it could interfere with operation. It is also possible that children may play around with the sensor. Take preventative measures as necessary.

NOTES: The STBY [SW -] in the main unit terminal block can be used as a communication "normally open" input terminal. If the switch is in the closed position, the operation is the same as if the TALK button were pushed. Use the method most suitable for your needs.

Rated voltage: DC 30 V

Rated current: 15 mA

Contact resistance: 100 Ω or less

Cable layout length: Maximum 20m, 65'(Ø0.65 mm (22AWG) to 1.2 mm (16AWG))

For details, please contact your local distributor.

# 5 WIRING DIAGRAM

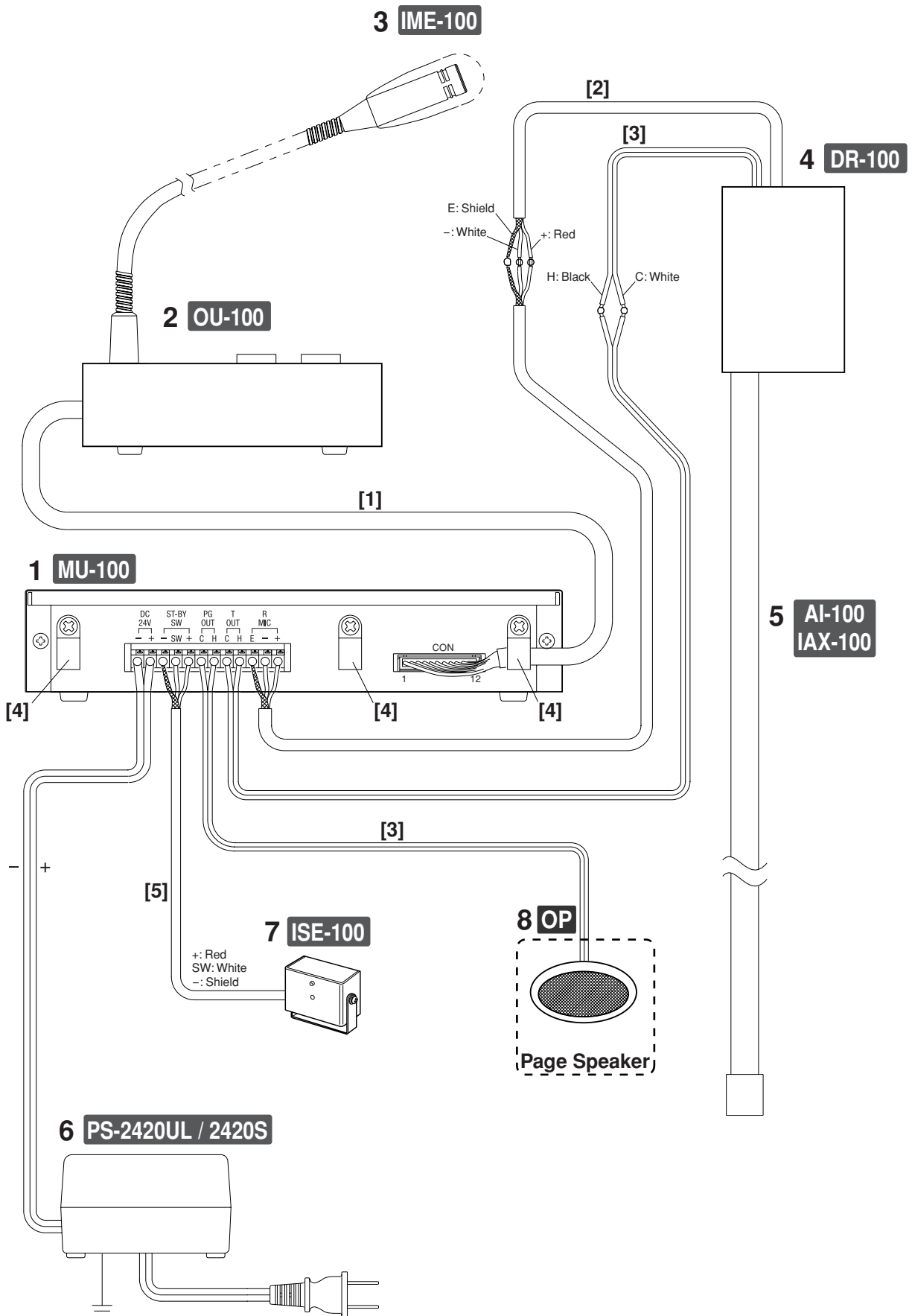



## 5-1

### Wiring

English

1. Main unit MU-100
2. Operation unit OU-100
3. Gooseneck microphone IME-100
4. Driver unit DR-100
5. Acoustic I/O tube AI-100 and acoustic tube IAX-100
6. Power supply adapter PS-2420UL/2420S
7. Sensor ISE-100
8. Paging speaker (option)

⚠ Suitable paging speakers have 4 to 6  $\Omega$  impedance and rated input of 3W or more, with a maximum input of 6W or more.

[1] Special connection cord for operation unit and main unit (approximately 2m,6'6").

⚠ Be sure to insert the cables to the correct polarity.

[2] Microphone cable:  $\varnothing$ 0.65 mm (22AWG) to 1.2 mm (16AWG) 2-conductor shielded cable

⚠ Be sure to insulate the joints of the cable.

[3] Speaker cable:  $\varnothing$ 0.9 mm (19AWG) to 1.2 mm (16AWG) cable

⚠ Be sure to insulate the cable splices.

[4] Wire Clamp

[5] Connection cord (approximately 3.5m, 11'5")

## 5-2

### Cable layout

English

1. Use the special cable provided with the operation unit to connect the operation unit with the main unit.
2. Receive input microphone cable layout
  - Use a 2-conductor shielded cable with a high shielding effect.
  - Splice the cable from the microphone to the terminal block on the main unit.
  - Be sure to splice the cable with the correct polarity.
3. Transmit output speaker cable layout
  - Use a cable of  $\varnothing$ 0.9 mm (19AWG) specification or more.
  - Splice the cable from the speaker to the terminal block of the main unit.
  - A twisted pair cable is suitable for the speaker.
  - Be sure to splice the cable with the correct polarity.

## 5-3

### Wiring distance

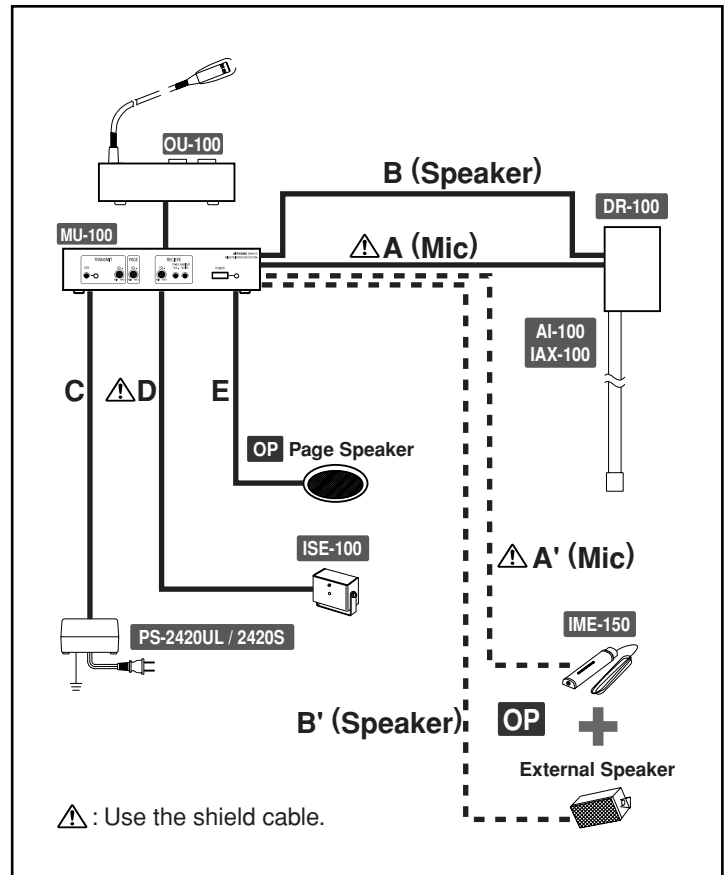

	$\varnothing$ 0.65~1.2 mm	AWG22~AWG16
A	20 m (max.)	66'(max.)
A'	20 m (max.)	66'(max.)
D	20 m (max.)	66'(max.)
	$\varnothing$ 0.9~1.2 mm	AWG19~AWG16
B	20 m (max.)	66'(max.)
B'	20 m (max.)	66'(max.)
C	20 m (max.)	66'(max.)
E	20 m (max.)	66'(max.)

## 6 NAMES

### Names

English

#### OU-100

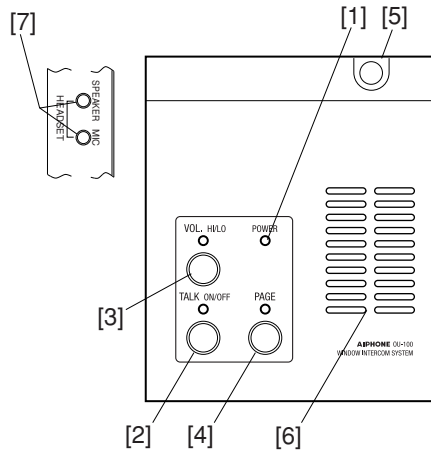

#### MU-100

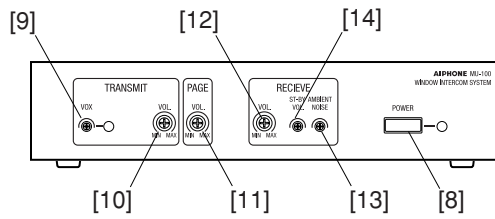

- [1] POWER LED (green)
- [2] TALK switch (orange)
- [3] VOL switch (orange)
- [4] PAGE switch (orange)
- [5] Gooseneck microphone
- [6] Receive speaker
- [7] Headset connectors
- [8] POWER switch
- [9] VOX sensitivity knob
- [10] Transmit volume knob
- [11] Paging volume knob
- [12] Receive volume knob
- [13] Noise canceling control knob
- [14] Standby volume knob



## 7 SETTING UP

OU-100

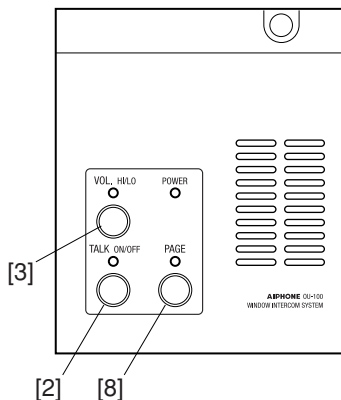

MU-100

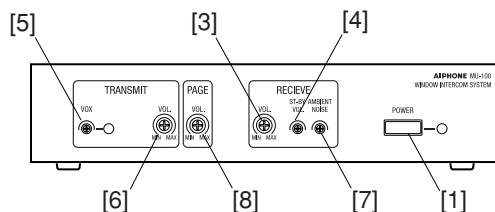

### Setting up

English

First, check that all the installation and wiring work has been completed, that all switches are off, and that all control knobs have been turned to the counterclockwise position.

[1] Turn on the power supply adapter and turn on the POWER switch of the main unit.

[2] Turn on the TALK switch of the operation unit so that communication is possible.

[3] Adjust the receive volume.

- Have someone stand and talk in the position on the customer side where the customer would stand, and turn the receive volume knob clockwise to adjust to a suitable volume.

- Do not set the volume too high as it could cause problems such as feedback or detection by the transmit VOX circuit.

⚠ Perform while the VOL switch of the operation unit is in the HI position.

[4] Adjust the receive volume in the standby mode. Adjust the volume if necessary.

- Have someone stand and talk in the position on the customer side where the customer would stand, and turn the standby volume knob clockwise to adjust to a volume suitable for the standby mode. The volume at the maximum clockwise position is one half of the volume when it is on. There is no sound at the initial counterclockwise position.

- When a suitable volume has been reached, turn the TALK switch on and off to check the difference in volume during communication and during standby.

⚠ Test while the VOL switch of the operation unit is in the HI position.

[5] Adjust the sensitivity of the VOX circuit.

- With the equipment arranged as it would be during use, have someone talk from the operator position. Adjust the VOX sensitivity knob by turning it clockwise so that it responds to the voice and the green LED illuminates. Adjust so that it illuminates when voice transmission starts and goes out when transmission ends.

- When stable and the LED is flashing, the minimum knob position is the most suitable. Adjustment is easier if the transmitted sound is checked on the customer side at the same time. It should be noted that sound from the customer side is blocked while the LED is illuminated.

⚠ Start by turning the VOX sensitivity knob and transmit volume knob a little clockwise so that the transmitted sound can be heard on the customer side.

[6] Adjust the transmit volume.

- Have someone talk from the operator position, and turn the transmit volume knob clockwise to adjust to a suitable volume for the customer side.

- Do not set the volume too high as it could cause problems such as feedback.

- Adjust the sensitivity of the VOX circuit again if necessary.

⚠ Test while the VOL switch of the operation unit is in the HI position.

[7] Adjust the noise canceling control knob.

- This function reduces the noise received from around and behind customer. Adjust as necessary. Have someone make a noise that you wish to reduce, and turn the noise canceling control knob clockwise or counterclockwise. Set at a level where the background noise is reduced.

- Next, have someone speak from the customer position and check that the volume of the received voice is not affected. Give priority to setting the optimum volume for the voice of the customer. This function is designed to reduce the volume of the background noise, not to eliminate it completely.

⚠ If there are no problems with the control position set at the time of shipment (minimum position, turned fully counterclockwise), then adjustment is unnecessary.

Adjustment is easier if the headset is used (use speaker side only). Even if the gooseneck microphone and built-in speaker are used with the operation unit, it is recommended that the headset be temporarily connected to perform the adjustment.

[8] Adjust the paging volume.

- Have someone talk from the operator position while pushing the PAGE button. Turn the PAGE volume knob clockwise to adjust until a suitable volume is heard from the paging speaker.

- Adjust while giving priority to one of the transmit, receive or standby modes of the paging broadcast.

⚠ 1. Adjustment is only necessary in a system where a paging speaker has been installed.

⚠ 2. Test while the VOL switch of the operation unit is in the HI position.

## 8 OPERATIONS

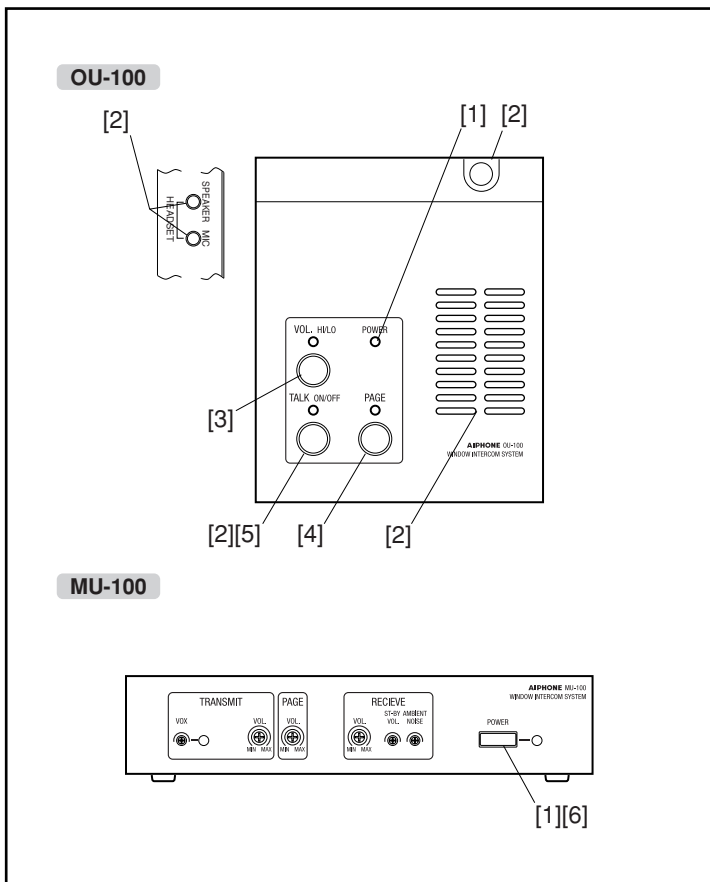

### Operation

English

- [1] Turn on the POWER switch of the main unit. The green lamp illuminates to show that electricity is being supplied and the system can be used.
- [2] Turn on the TALK switch of the operation unit. The orange lamp illuminates to show that communication is possible.
  - The voice from the customer side can be heard from the receive speaker built in to the operation unit.
  - ⚠ If a headset is connected, the receive sound is heard through the speaker(s) in the headset. During transmission, direct your voice towards the microphone of the headset.
  - When using a gooseneck microphone, you should direct your voice towards the gooseneck microphone during transmission. The VOX function is activated when the voice is output from the operator to the speakers on the customer side. During this output, the voice from the customer side is blocked. Be aware that during transmission, priority is automatically given to the voice from the operator side.
  - ⚠ If a headset is connected, the receive sound is heard through the speaker(s) in the headset. During transmission, direct your voice towards the microphone of the headset.
- [3] Change the VOL switch of the operation unit between HI and LO as necessary. The orange LED illuminates when it is in the HI position.
- [4] If the PAGE switch is pressed during transmission, even if the TALK switch is off, customers can be called or an announcement can be broadcast via the paging speaker. The orange LED illuminates while the button is pressed, and the function is cancelled when the button is released.
- [5] Turn off the TALK switch of the operation unit to switch to standby mode. When switched to standby mode, the transmission is blocked and the received sound volume is reduced.
- [6] When the system is not in use, press the POWER switch on the main unit to turn off the system.

## 9 SPECIFICATIONS

### 9-1

#### Specifications (main kit IMU-100) English

- Power source: DC 24V
- Current consumption: 120 mA (standby) 780 mA (maximum)
- Operating temperature: 0 °C to 40 °C
- Communication: Voice-actuated communication  
Transmit output: 3 W 4 Ω  
Receive output: 1.5 W 16 Ω
- Headset: Ø3.5 plug  
Impedance: 32 Ω  
Rated input: 40 mW or more  
Maximum input: 100 mW or more
- External speaker: Impedance: 4 to 8 Ω  
Rated input: 3 W or more  
Maximum input: 6 W or more
- Paging speaker: Impedance: 4 to 8 Ω  
Rated input: 3 W or more  
Maximum input: 6 W or more
- Material: Steel plate
- Dimensions: Main unit MU-100:  
210 mm (width) x 45 mm (height) x 206 mm (depth)  
Operation unit OU-100:  
130 mm (width) x 49 mm (height) x 160 mm (depth)
- Weight: Main unit MU-100:  
Approx. 1.3 kg (2.87 lbs.)  
Operation unit OU-100:  
Approx. 700 g (1.55 lbs.)

### 9-2

#### Specifications (gooseneck microphone IME-100) English

- Microphone: Type: Condenser microphone  
Directivity: Uni-directional  
Input sensitivity: -46 dB
- Dimensions: 510 mm (length of gooseneck)
- Weight: Approx. 190 g (0.42 lbs.)

### 9-3

#### Specifications (acoustic interface kit IAI-100) English

- Operating temperature: 0 °C to 40 °C
- Acoustic output: Impedance: 4 Ω  
Rated input: 4.5 W  
Maximum input: 6 W
- Microphone: Type: Condenser microphone  
Directivity: Non-directional  
Input sensitivity: -41 dB
- Material: Aluminum  
Speaker fixing plastic: ABS plastic fire resistance 94V-0
- Dimensions: Driver unit DR-100:  
84 mm (width) x 150 mm (height) x 36 mm (depth)  
Acoustic I/O tube AI-100:  
27 mm (width) x 388 mm (height) x 24 mm (depth)
- Weight: Driver unit DR-100:  
Approx. 300 g (0.66 lbs.)  
Acoustic I/O tube AI-100:  
Approx. 400 g (0.88 lbs.)

### 9-4

#### Specifications (acoustic tube IAX-100) English

- Material: Aluminum
- Dimensions: 27 mm (width) x 1,000 mm (height) x 24 mm (depth)
- Weight: Approx. 650 g (1.43 lbs.)

### 9-5

#### Specifications (sensor ISE-100) English

- Power source: DC 24V
- Current consumption: 5 mA (standby) 13 mA (maximum)
- Operating temperature: 0 °C to 40 °C
- Material: Aluminum
- Dimensions: 68 mm (width) x 50 mm (height) x 30 mm (depth)
- Weight: Approx. 120 g (0.26 lbs.)

### 9-6

#### Specifications (optional microphone IME-150) English

- Microphone: Condenser microphone, Non-directional
- Dimensions: 23 mm (width) x 115 mm (height) x 13 mm (depth)
- Weight: Approx. 150 g (0.31 lbs.)

## WARRANTY

Aiphone warrants its products to be free from defects of material and workmanship under normal use and service for a period of two years after delivery to the ultimate user and will repair free of charge or replace at no charge, should it become defective upon which examination shall disclose to be defective and under warranty. Aiphone reserves unto itself the sole right to make the final decision whether there is a defect in materials and/or workmanship; and whether or not the product is within the warranty. This warranty shall not apply to any Aiphone product which has been subject to misuse, neglect, accident, or to use in violation of instructions furnished, nor extended to units which have been repaired or altered outside of the factory. This warranty does not cover batteries or damage caused by batteries used in connection with the unit. This warranty covers bench repairs only, and any repairs must be made at the shop or place designated in writing by Aiphone. Aiphone will not be responsible for any costs incurred involving on site service calls.



*Providing Peace of Mind*

<http://www.aiphone.com/>

AIPHONE CO., LTD., NAGOYA, JAPAN  
AIPHONE CORPORATION, BELLEVUE, WA, USA  
AIPHONE S.A., WISSOUS, CEDEX, FRANCE

Printed in Japan