



ATMOD

Installation Note

Pre-built End of Line (EOL) resistor module with quick-connect terminals for security and access control systems.

Termination

Strip the wires from the alarm sensor, reed switch, push button or other device so that about 5mm of conductor is exposed. Evenly twist the strands to make the conductor more ridged then insert into the round terminals at the tabbed end of the ATMOD. Ensure that the wire insulation ends inside the ATMOD terminal so that no conductor strands are exposed. A twisting motion may help insert the conductor.

Repeat this action for the wires from the alarm panel, inserting these wires into the end of the ATMOD that has no tab. There is no need to observe polarity at either end of the ATMOD. If the ATMOD is installed in a difficult-to-access area, or if there is a chance the cables may be put under stress, then fold the wires back across the ATMOD and secure at the centre of the ATMOD with a 2mm cable tie, as illustrated.

To use the ATMOD with alarm devices that do not have fly leads, such as a break glass unit, simply use two short lengths of insulated wire as the connection between the device and the ATMOD. The ATMOD terminals are also suitable for tinned conductors. Further labour savings can be made by fitting the ATMOD to field devices in the workshop prior to going to site. Installation on site is then much more efficient.

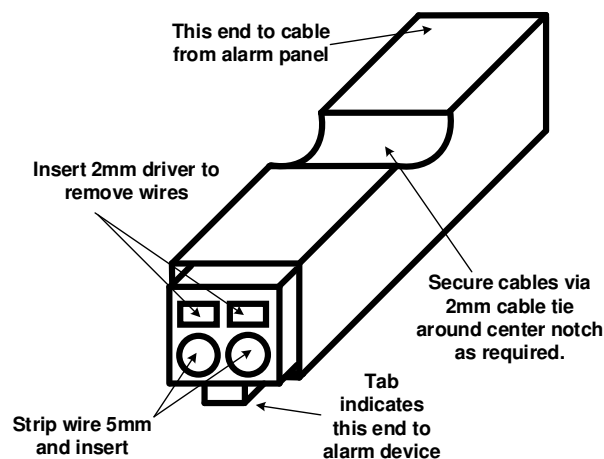

Removal

To remove the wires from the ATMOD just insert a 2mm terminal driver into the slot above the wire you wish to remove then gently pull the wire. The ATMOD can be reused several times however the spring terminals will become less secure with each use.

Shared Common

To use the ATMOD with devices that share a common output wire, such as some mortice locks, it is important to wire the ATMOD in the correct method. This will ensure the common connection continues through to the alarm panel.

It is a good practice to always wire the common conductor in this method and keep the wire insulation colours the same.

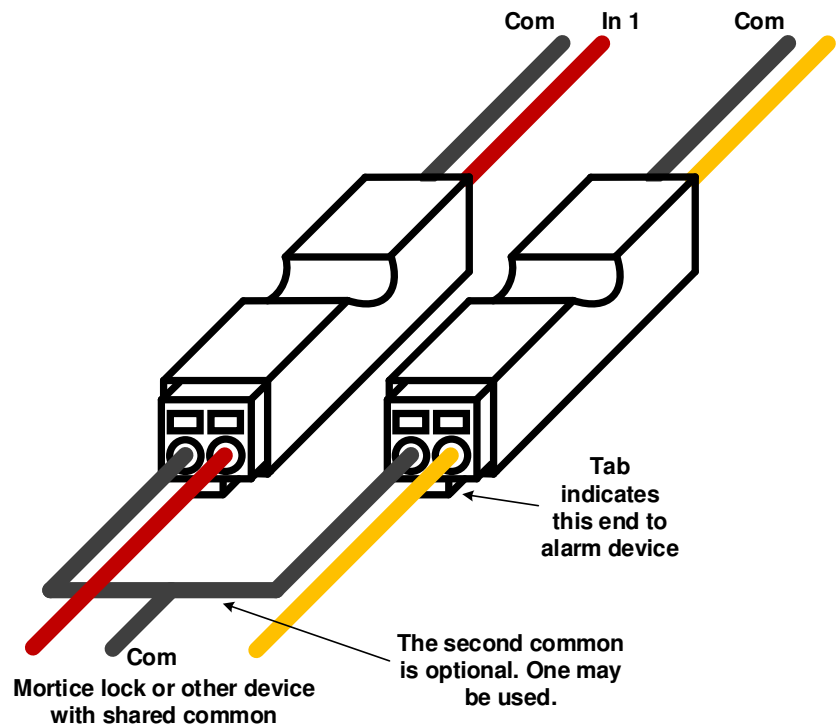
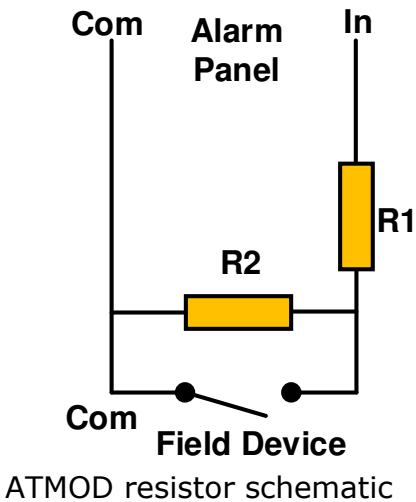

Technical Data

Minimum conductor size (Stranded)	.2mm ² (24AWG)
Maximum conductor size	.5mm ² (20AWG)
Dimensions	24 L X 7 W X 8 H (mm)

Ordering Code

ATMOD01	ATMOD with 1K/1K resistors	Black
ATMOD22	ATMOD with 2K2/2K2 resistors	Green
ATMOD47	ATMOD with 4K7/4K7 resistors	Yellow
ATMOD10	ATMOD with 10K/10K resistors	RED
ATMOD-S	ATMOD with resistor values to suit your application, contact Jack Fuse	

Learning

Become a **Jack Fuse Product and Power Certified Technician**. Free training available online.

More Information: For complete installation notes, data sheets and technical support please visit www.jackfuse.com

