

# TAKEX

# PASSIVE INFRARED SENSOR

## Instruction Manual

PA-15WE (Wide angle, 15m)

PA-30NE (Long range, 30m)

Thank you for purchasing this TAKEX passive infrared sensor.

This sensor will provide long and dependable service when properly installed.

Please read this Instruction Manual carefully for correct and effective use.

**Please note :** This sensor is designed to detect passing objects and to initiate a signal ; it is not a burglary-preventing device. TAKEX is not responsible for damage or losses caused by accident, theft, Acts of God (including lightning), abuse, misuse, abnormal usage, faulty installation or improper maintenance.

## 1 PARTS DESCRIPTION

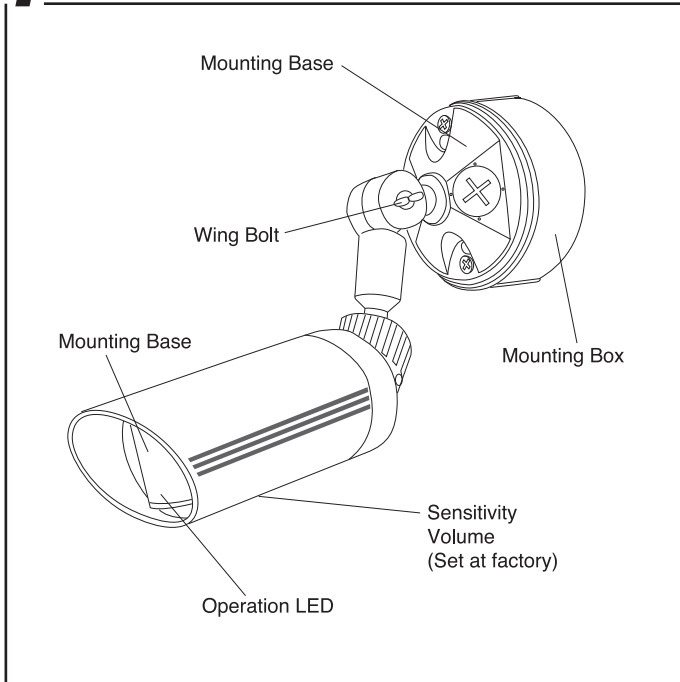

## 2 WIRING

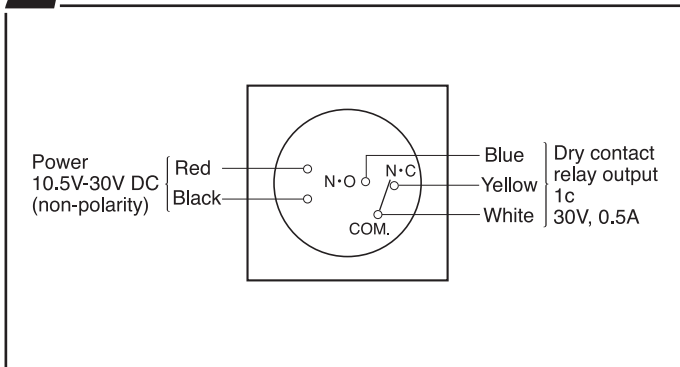

## 3 INSTALLATION

### DO'S AND DON'T'S

- Install the sensor in such a direction that people are more likely to cross the detection zones.
- Do not install in a site which is directly by an air conditioning exhaust vent.
- Avoid direct sun light shining on the window of the sensor.
- Do not install in a site which is subject to electrical noise.
- Install sensor with its sensitivity volume downward.

## HOW TO INSTALL

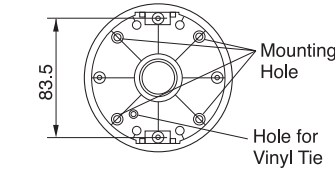

- (1) Install Mounting Box. Break knockouts (mounting holes) from inside with a screw driver, etc. Tighten screws provided.

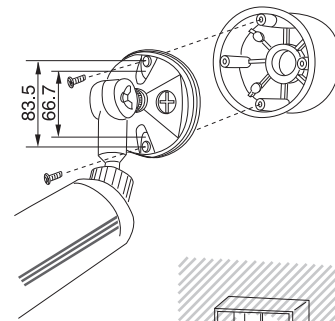

- (2) Refer to 2. WIRING and connect wires. Tie up wires inside the box with a vinyl tie provided.

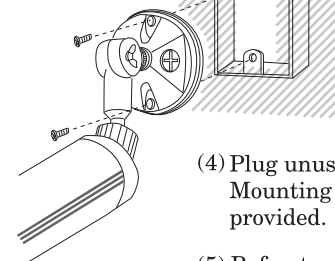

- (3) Attach Sensor Unit to Mounting box with screws provided. You can install the sensor to standard single gang electrical box (pitch : 83.5 or 66.7mm) available in

- (4) Plug unused screw holes on Mounting Base with push rivets provided.

- (5) Refer to 4. ANGLE ADJUSTMENT and adjust the angle of the sensor.

**NOTE :** Wire through the lower wire lead access on Mounting Box to prevent water leakage.

## 4 ANGLE ADJUSTMENT

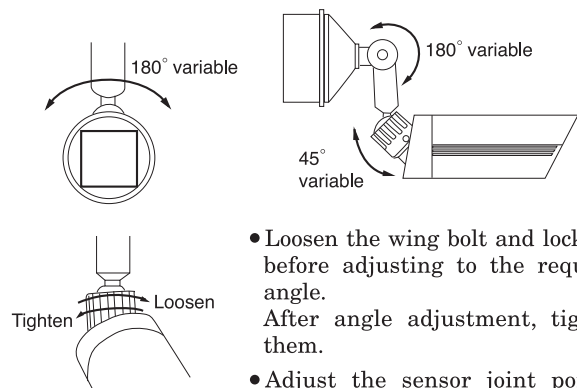

- Loosen the wing bolt and lock nut before adjusting to the required angle. After angle adjustment, tighten them.
- Adjust the sensor joint portion according to the figure.
- Do not fail to set Sensor Unit to a lower angle than horizontal.

# 5 ADJUSTMENT

## (1) Operation Check

Check operation after installation is completed.

1. Allow approx. 1 minute to warm up after power is applied.
2. After 1 minute, operate a walk test in the protected area to check if the alarm is activated. (Operation LED (red) lights when an alarm is initiated.)

## (2) Sensitivity adjustment (sensitivity volume)

It is usually unnecessary to adjust sensitivity which has been set at the factory. Adjust sensitivity to low if small animals activate the sensor.

# 6 TROUBLESHOOTING

Analyze possible problems according to the following table. If normal operation can not be restored by these procedures, contact either the dealer from whom you bought the unit or TAKEX.

Symptom	Passive Cause	Remedy
Completely inactive (Operation LED doesn't lights.)	<ul style="list-style-type: none"> <li>●No power supply, broken wire or incorrect voltage.</li> <li>●Window shielded by an opaque substance.</li> <li>●Sensitivity adjustment too low.</li> </ul>	<ul style="list-style-type: none"> <li>●Correct power supply or replace the broken wire.</li> <li>●Remove the shielding substance.</li> <li>●Turn sensitivity up and re-check operation.</li> </ul>
Frequent alarm (Operation LED lights too often.)	<ul style="list-style-type: none"> <li>●Incorrect power supply.</li> <li>●Something moving in protected area or rapid temperature variations.</li> <li>●Large electrical noise source such as power machine nearby or wiring too close to that of the PIR.</li> </ul>	<ul style="list-style-type: none"> <li>●Correct power supply.</li> <li>●Remove the cause.</li> <li>●Turn the sensitivity down.</li> <li>●Relocate the device.</li> <li>●Change the path of wiring.</li> </ul>
Control panel fails to work although LED lights.	<ul style="list-style-type: none"> <li>●Poor contact, broken wire or defective insulation of signal line.</li> <li>●Damaged alarm contact.</li> </ul>	<ul style="list-style-type: none"> <li>●Check wiring with a tester.</li> <li>●Check alarm contact operation with a tester.</li> </ul>

# 7 SPECIFICATIONS

Passive infrared sensor	
Model	PA-15WE PA-30NE
Detection system	Passive infrared
Sensitive zone	24 (12 pairs) 2 (1 pair)
Coverage	Wide angle (Max. 50° (15m)) Long range (Max. 100° (30m))
Output signal	Dry contact relay 1C Reset : approx. 2 sec. Contact capacity : 30V, 0.5A (resistant load)
Operation LED	Red LED (Lights when sensor detects)
Supply voltage	10.5V DC to 30V DC (non polarity)
Current consumption	25mA or less
Ambient temperature range	-2° F to 122° F (-20° C to +50° C)
Mounting position	Indoor / Outdoor (Rain-proof)
Connection	Lead wire
Weight	17.5oz (500g)
Appearance	Sensor : PC resin (ivory) Mounting portion : AES resin (dark gray)

# 8 EXTERNAL DIMENSIONS

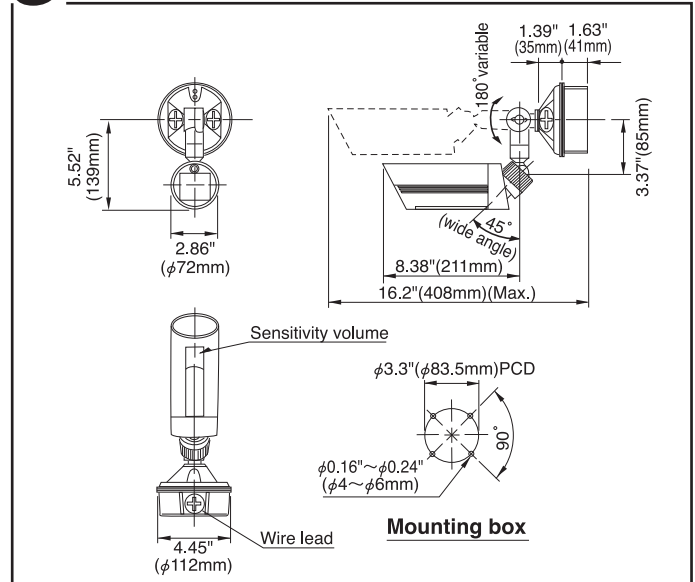

# 9 COVERAGE

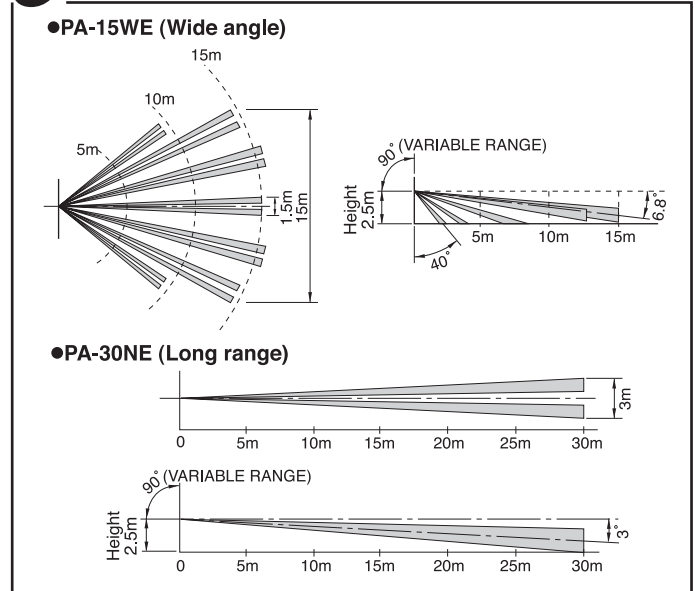

## Note :

TAKEX, passive infrared sensor is designed to detect infrared energy variation caused by the presence of a human body.

Therefore note that similar variation in conditions in the protected area, due to other reasons, may cause the sensor to create an alarm as it is unable to distinguish between the sources.

When the sensor is used outdoors, moving objects with heat source (wind, fallen leaves, small animals) may cause the sensor to create an alarm.

AVOID USING THE SENSOR FOR FULL-SCALE SECURITY PURPOSE.

## Limited Warranty :

TAKEX products are warranted to be free from defects in material and workmanship for 12 months from original date of shipment. Our warranty does not cover damage or failure caused by Acts of God (including inductive surge by lightning), abuse, misuse, abnormal usage, faulty installation, improper maintenance or any repairs other than those provided by TAKEX. All implied warranties with respect to TAKEX, including implied warranties for merchantability and implied warranties for fitness, are limited in duration to 12 months from original date of shipment. During the Warranty Period, TAKEX will repair or replace, at its sole option, free of charge, any defective parts returned prepaid. Please provide the model number of the products, original date of shipment and nature of difficulty being experienced. There will be charges rendered for product repairs made after our Warranty period has expired.

# TAKEX TAKENAKA ENGINEERING CO., LTD.

## In Japan

**Takenaka Engineering Co., Ltd.**  
83-1, Gojo-sotokan, Higashino,  
Yamashina-ku, Kyoto 607-8156, Japan  
Tel : 81-75-501-6651  
Fax : 81-75-593-3816  
<http://www.takex-eng.co.jp>

## In the U.S.

**Takex America Inc.**  
1330 Orleans Drive, Sunnyvale,  
CA 94089, U.S.A.  
Tel : 408-747-0100  
Fax : 408-734-1100  
<http://www.takex.com>

## In Australia

**Takex America Inc.**  
Unit 16/35 Garden Road, Clayton,  
3168 Victoria, Australia  
Tel : 03-9546-0533  
Fax : 03-9547-9450

## In the U.K.

**Takex Europe Ltd.**  
Takex House, Aviary Court, Wade Road,  
Basingstoke, Hampshire, RG24 8PE, U.K.  
Tel : (+44) 01256-475555  
Fax : (+44) 01256-466268  
<http://www.takexeurope.com>