

3500 EXT SERIES

HEAVY DUTY MAGNETIC DOOR HOLDER WITH EXTENSION



The 3500 EXT Series of magnetic door holders are specifically designed for fire and smoke doors with a 40kg holding force and titanium alloy surface finish. Elegant in appearance, this series is ideal for projects where doors are required to be held in the open position for both pedestrian and general traffic, the devices have to be linked into a buildings fire/smoke alarm system.

When an alarm occurs, power is removed from the devices and the doors are returned to the closed condition, preventing the spread of fire and/or smoke to other areas. The devices are fire tested to a rating of 4 hours and are supplied either 12 or 24VDC.

Technical Details

Part No.	35770/150/s	3577/150/s	35770/300/s	3577/300/s
Function	Heavy duty 150mm extension, wall mount magnetic door holder		Heavy duty 300mm extension, wall mount magnetic door holder	
Holding Strength	Up to 40kg			
Voltage/Current	12VDC/100mA	24VDC/50mA	12VDC/100mA	24VDC/50mA
Dimensions	D=207 x W=90 x H=90mm		D=355 x W=90 x H=90mm	

Part No.	35770/150/90	3577/150/90	35770/300/90	3577/300/90
Function	Heavy duty 150mm 90° extension, wall & floor mount magnetic door holder		Heavy duty 300mm 90° extension, wall & floor mount magnetic door holder	
Holding Strength	Up to 40kg			
Voltage/Current	12VDC/100mA	24VDC/50mA	12VDC/100mA	24VDC/50mA
Dimensions	D=117 x W=90 x H=176mm		D=117 x W=90 x H=324mm	

Product Features

- Fire rated (contact Allegion for more details)
- Up to 40kg holding force
- 12 and 24VDC option
- Floor mount and wall mount options
- 2 year warranty

Product Dimensions and Installation

WALL MOUNT

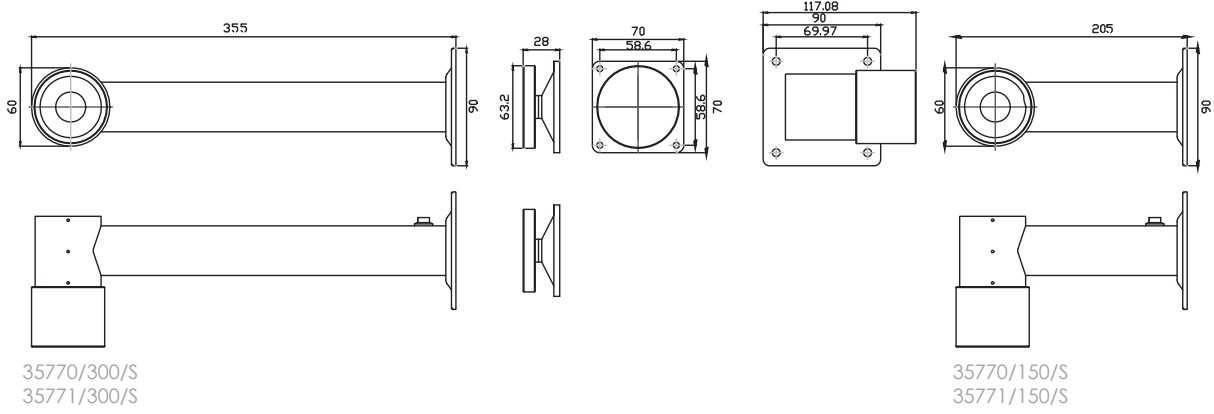

FLOOR MOUNT

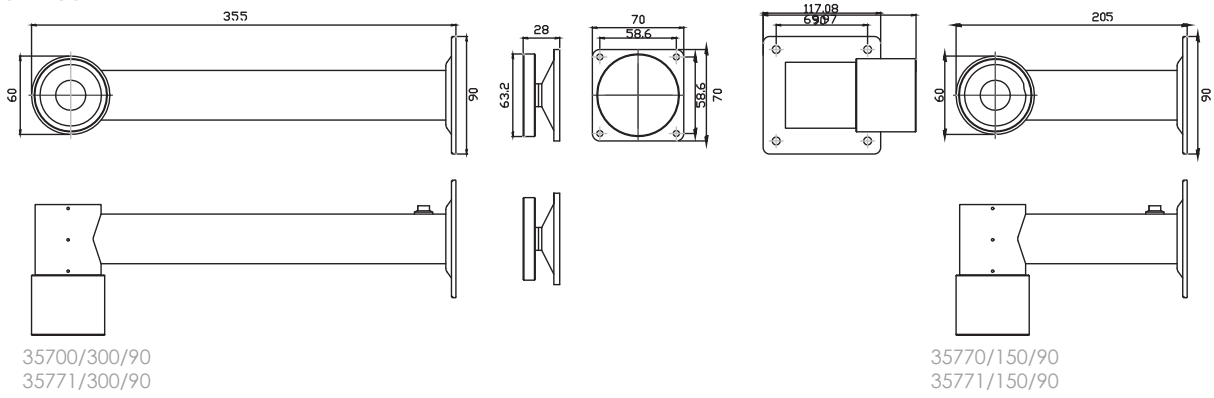

TYPE OF INSTALLATION

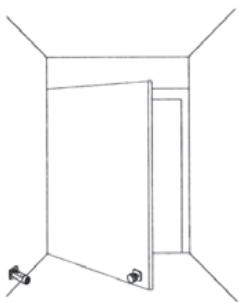

Extension Wall Mounting

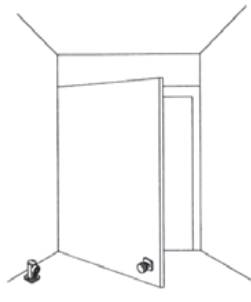

Floor Mounting

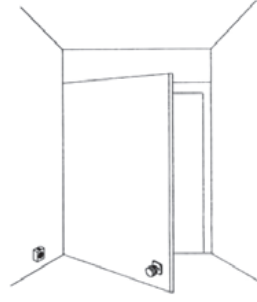

Wall Mounting